

# Sub di P. D'Auria

<http://www.origamidauria.it>

Usare un quadrato di carta metallizzata di almeno 24 cm di lato

1

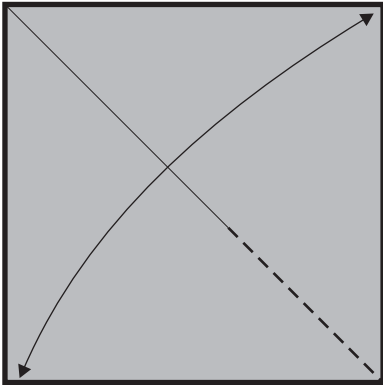

2

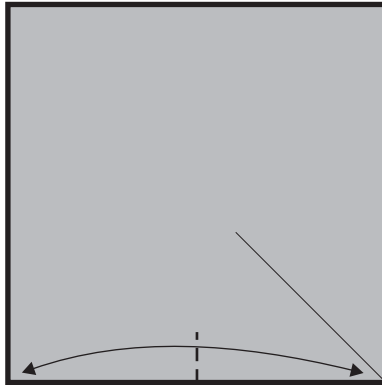

3

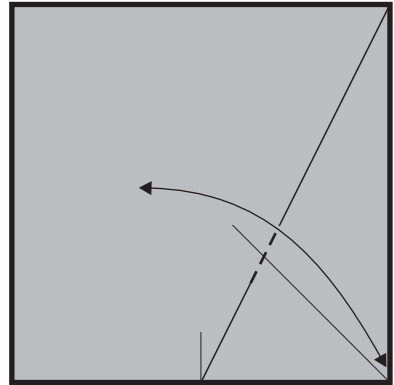

4

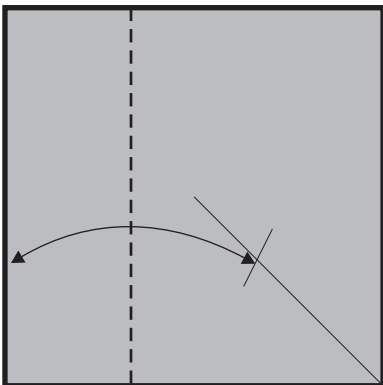

5

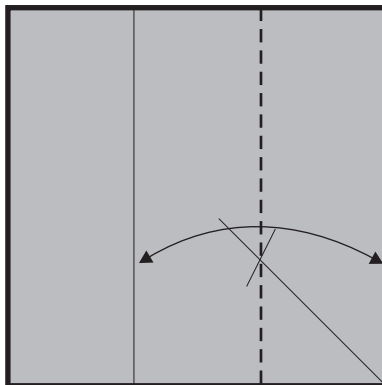

6

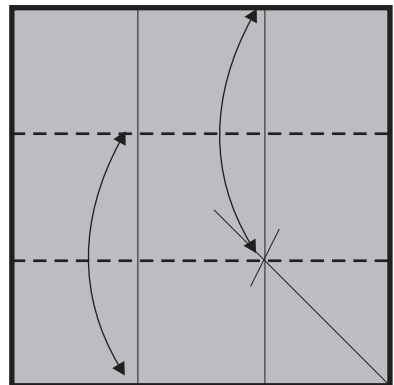

7

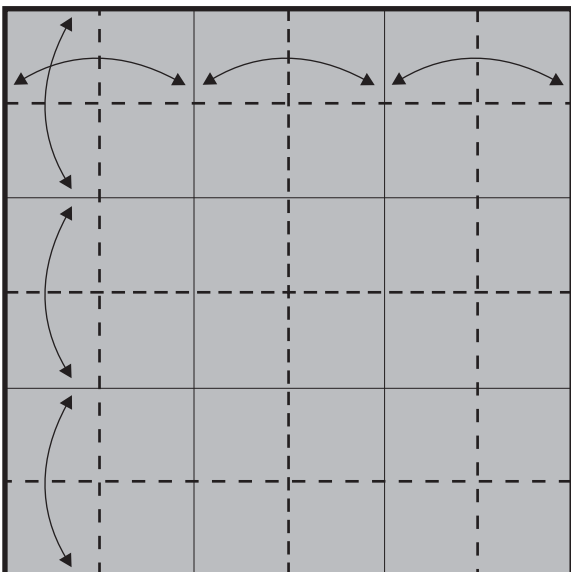

8

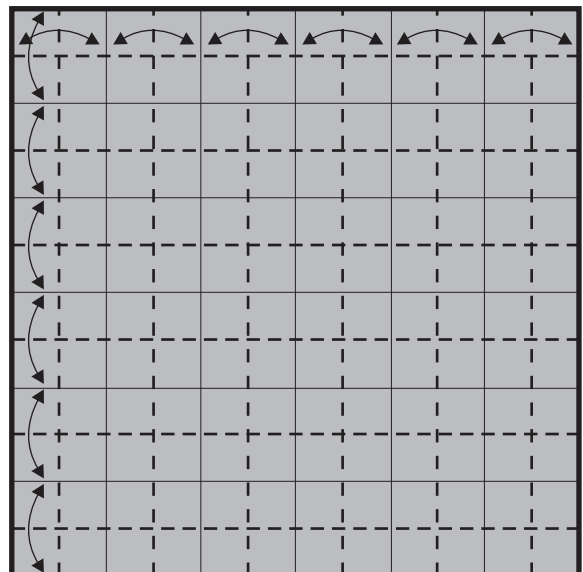

8



9

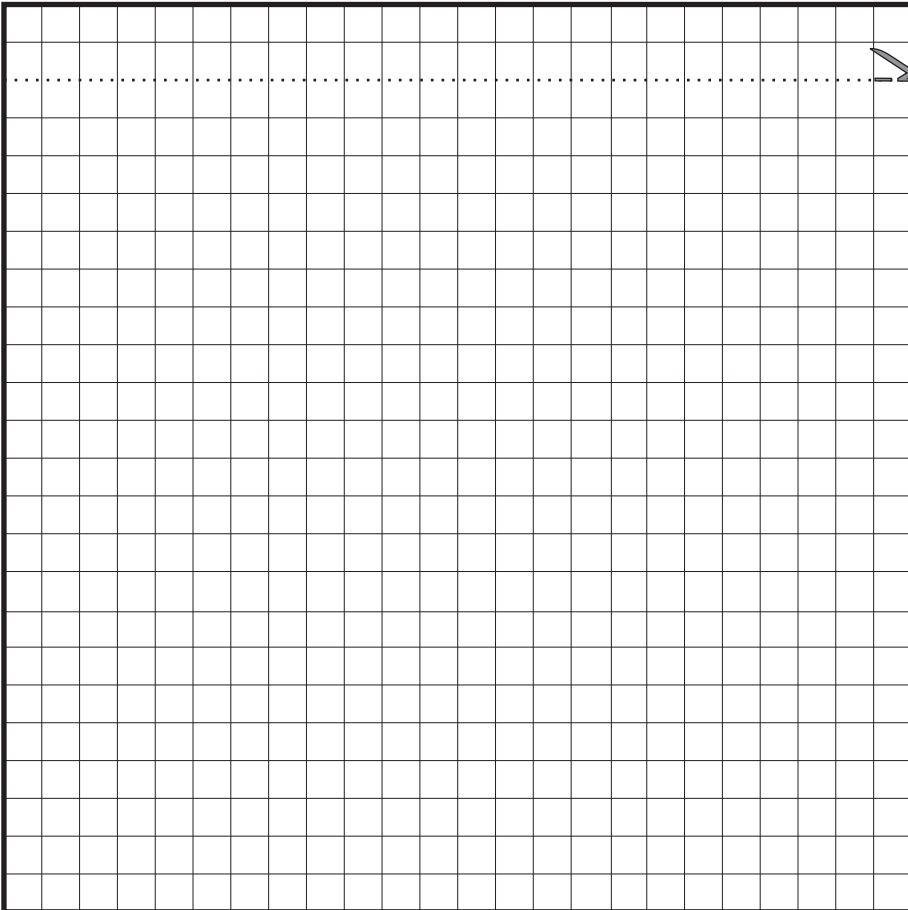
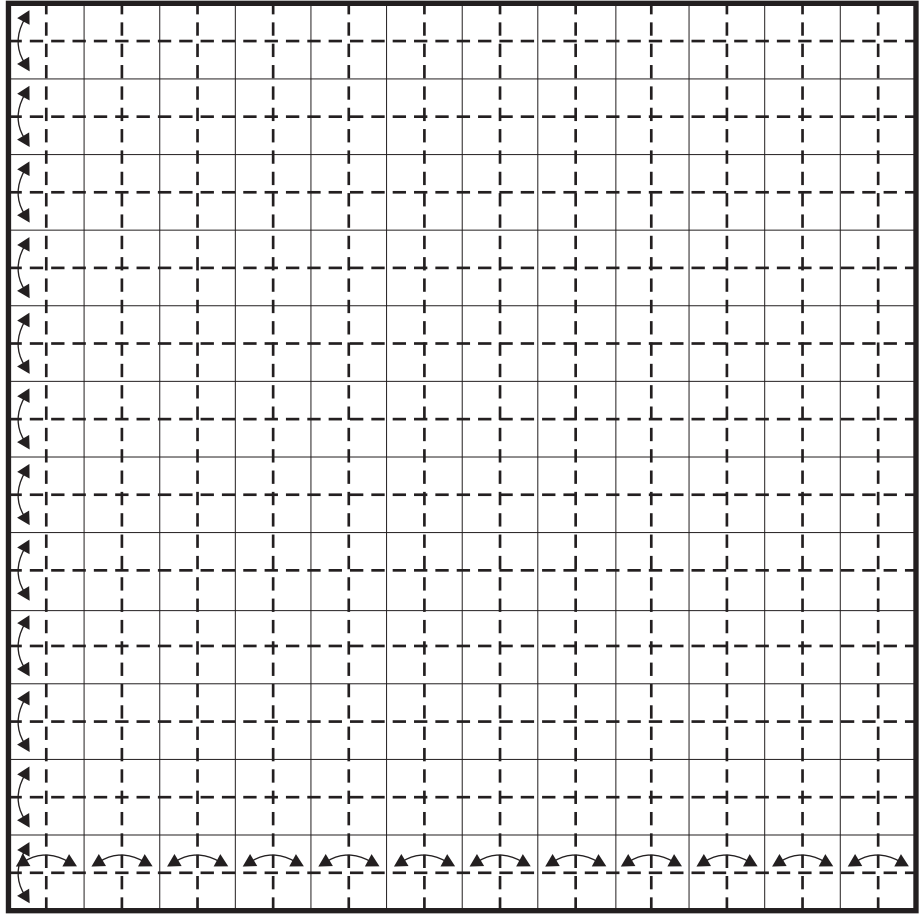

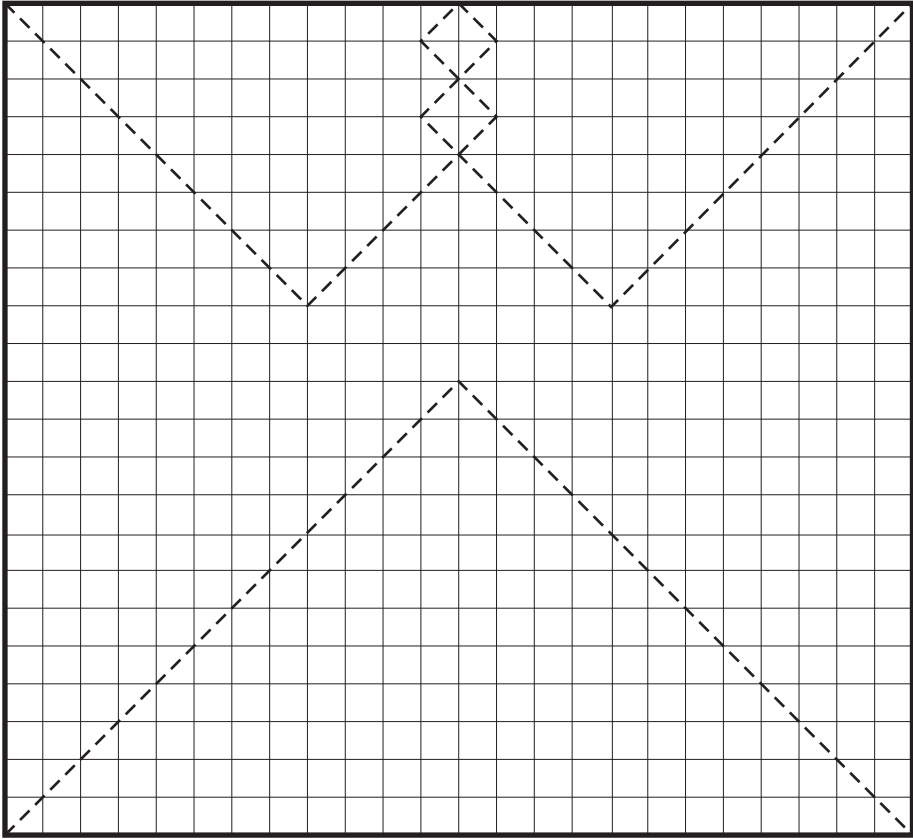

10

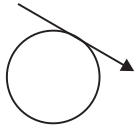

11

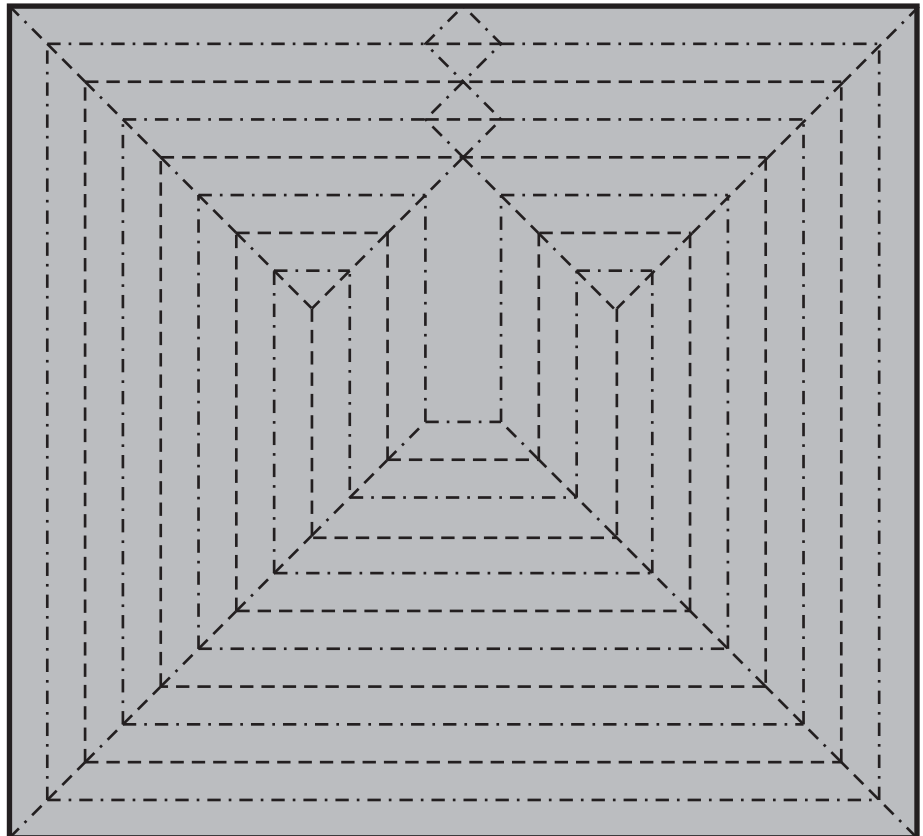

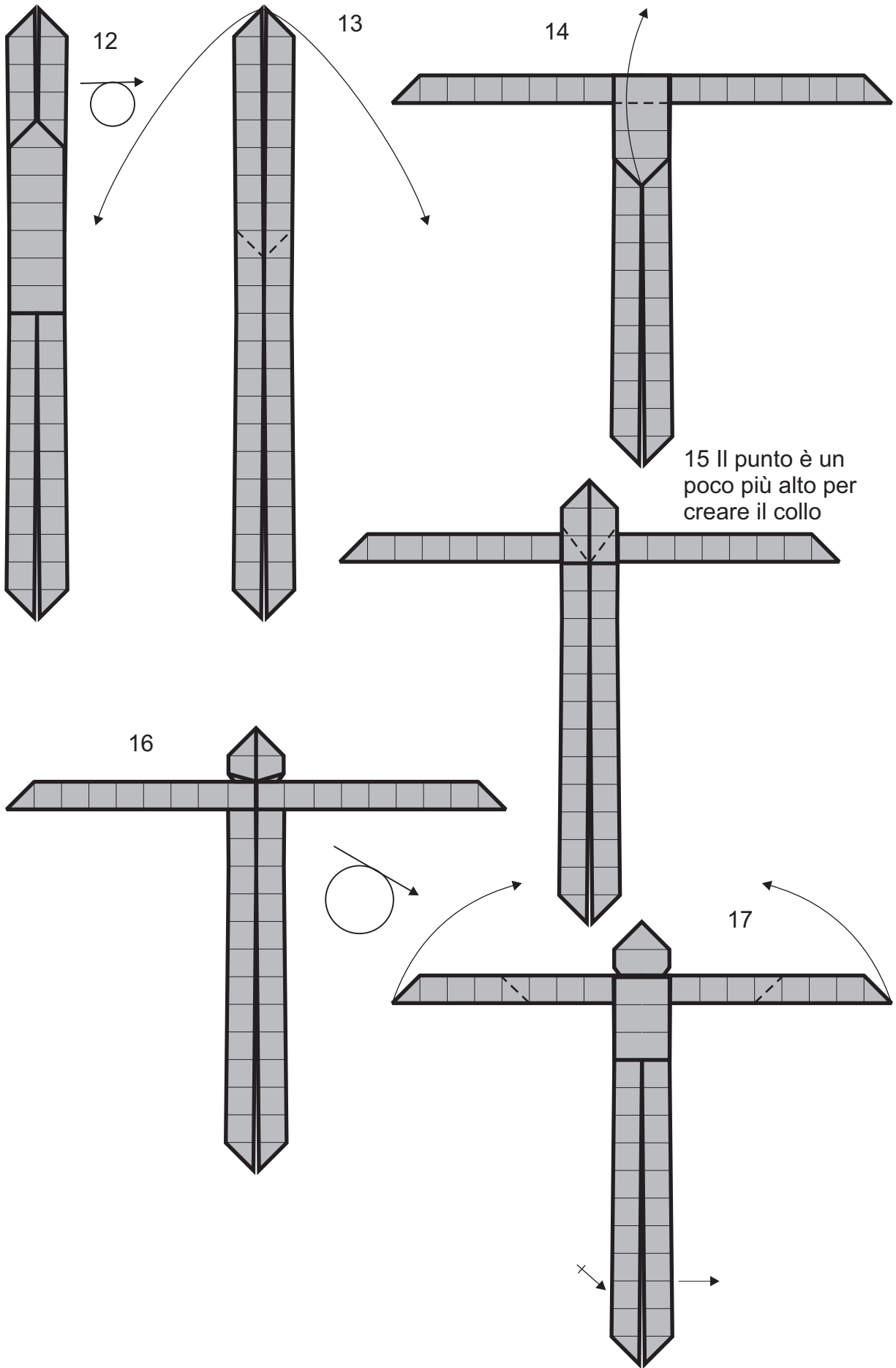

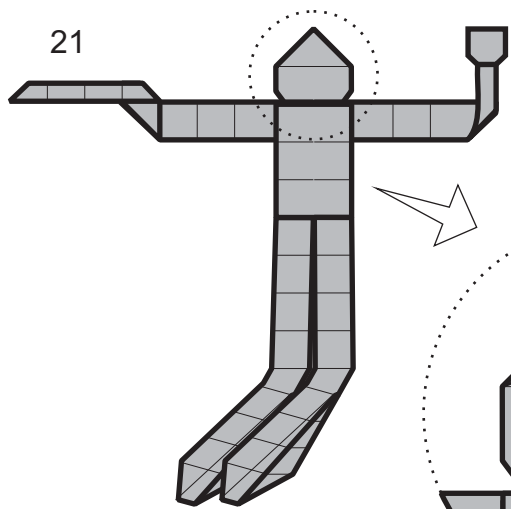
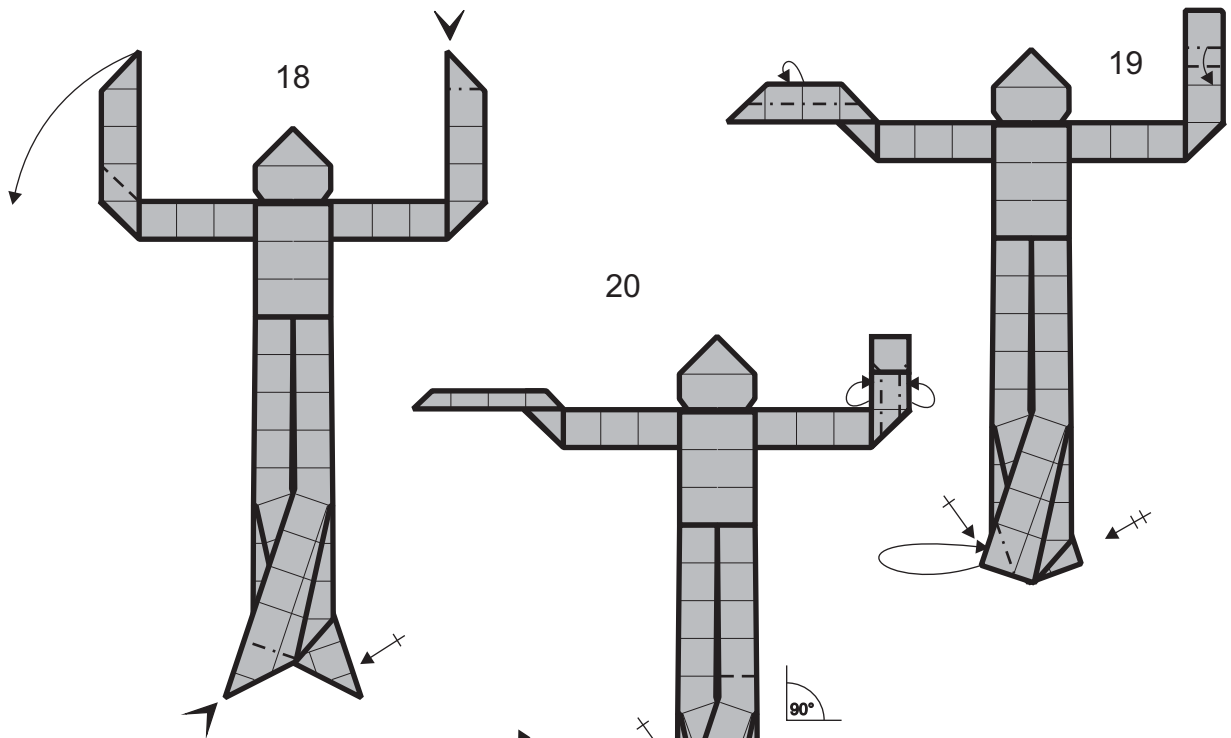

23 questa piega rende tridimensionale il naso

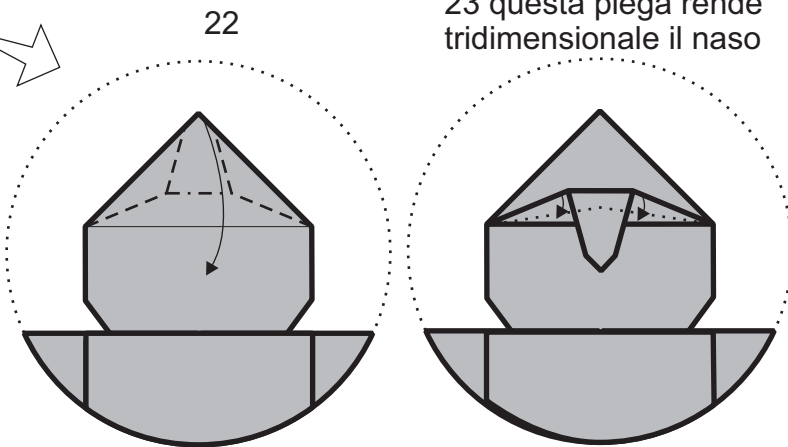

26 si deve modellare gli occhi della maschera

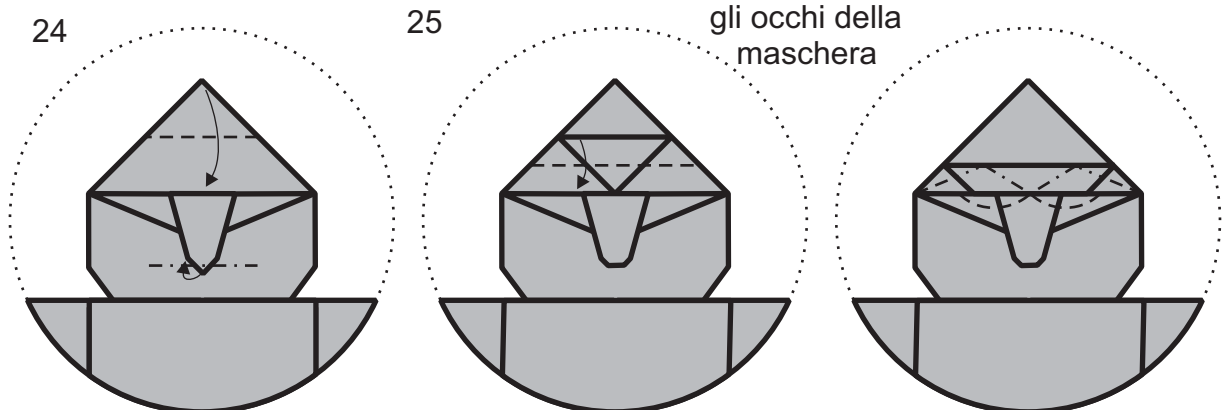

28 modellare la testa rendendola più naturale possibile

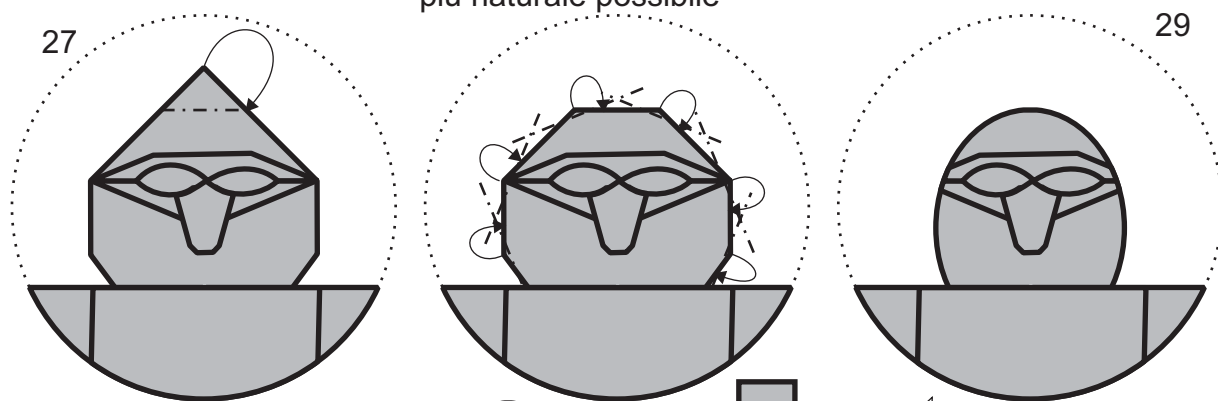

30 sia le pieghe della mano sia quelle delle gambe, non sono delle vere pieghe a valle o a monte, ma sono un modellare la carta

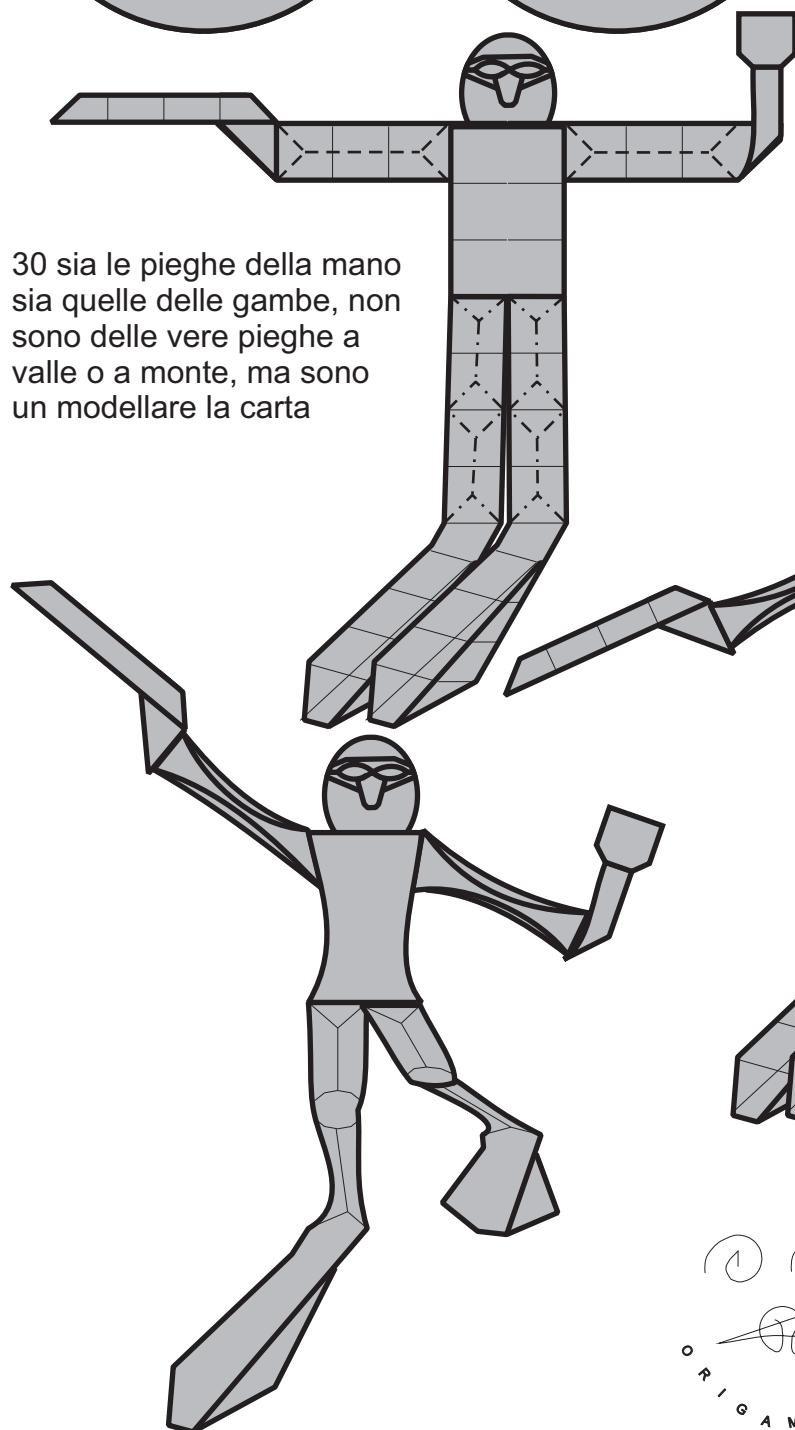

31 modellare il sub, guardando una foto cercando di creare una postura più naturale possibile.

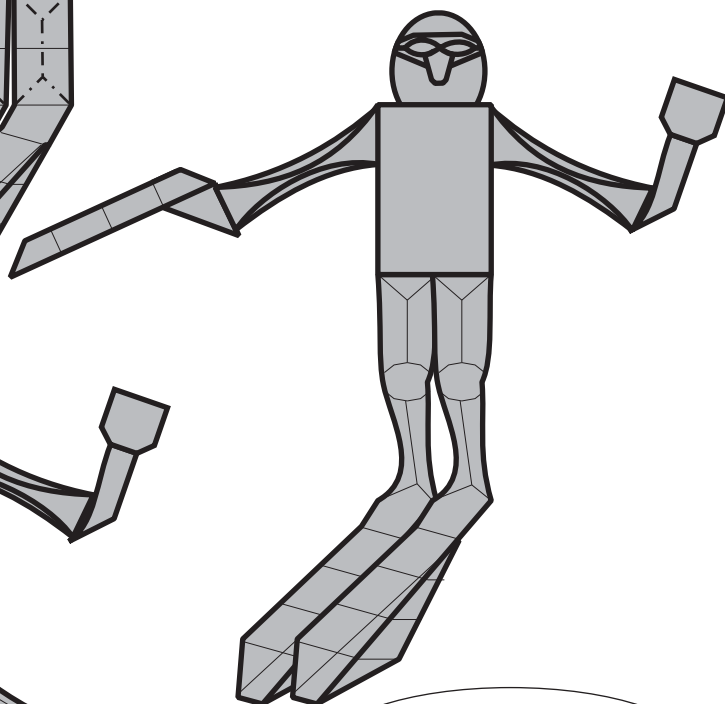

mi dicono che sei un sub eccezionale!

no! Sono solo un sub normale...

