

Scorpione 12.12

di P. D'Auria

<http://www.origamidauria.it>



Usare un quadrato di carta metallizzata con il lato di almeno 18 cm.

1

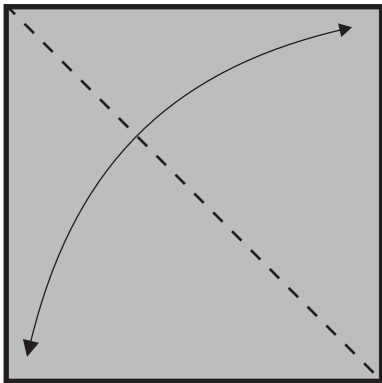

2

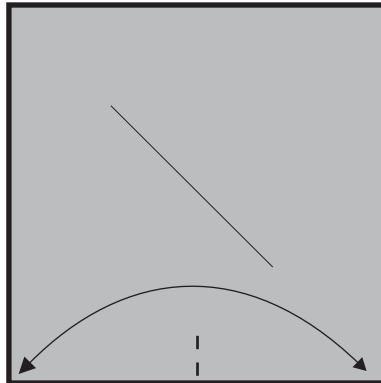

3

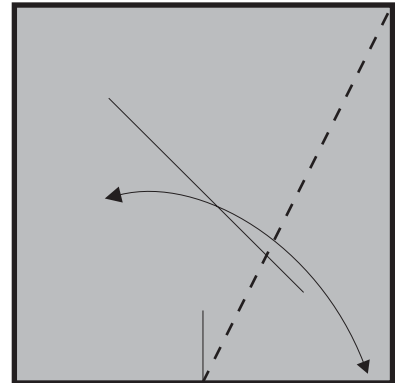

4

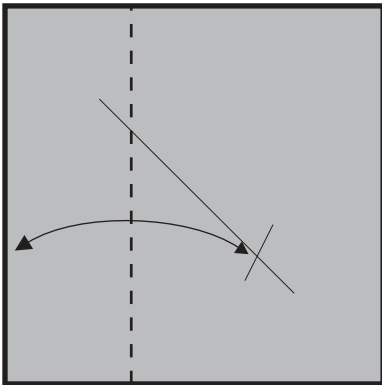

5

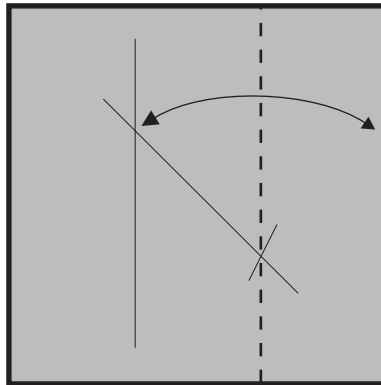

6

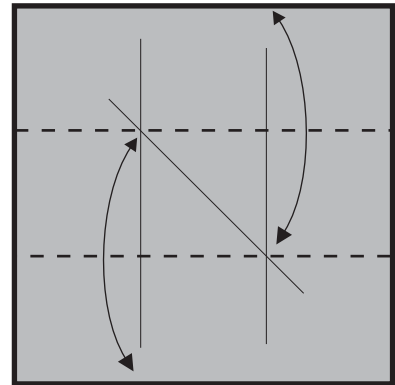

7

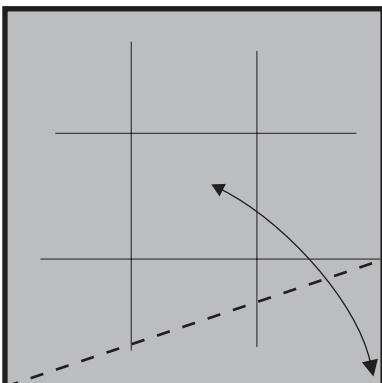

8

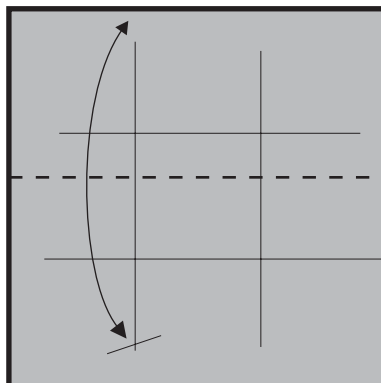

9

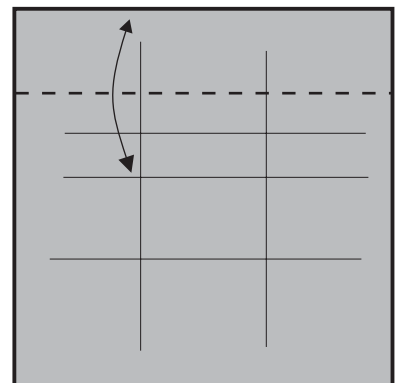

10

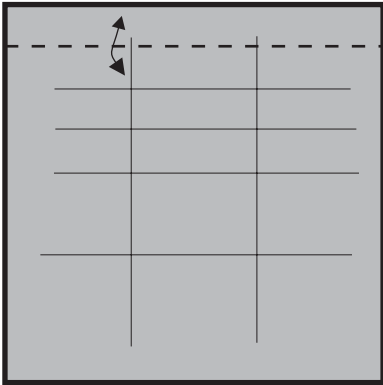

11

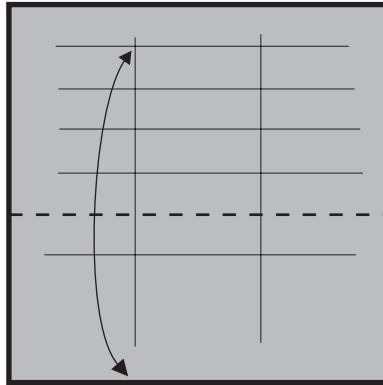

12

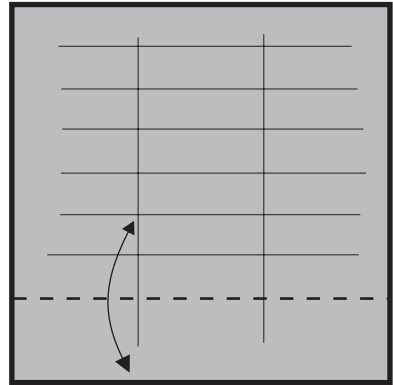

13

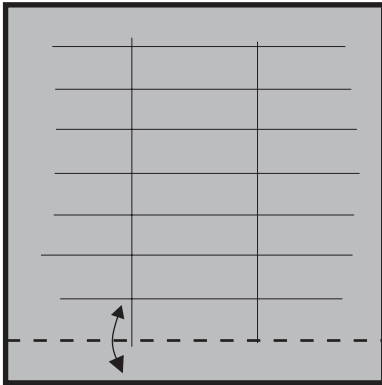

14

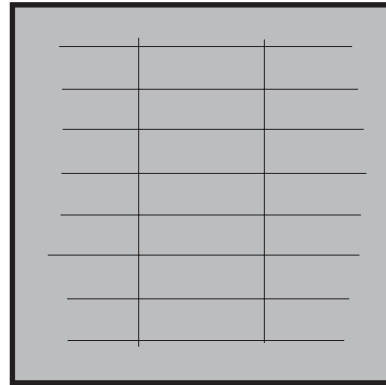

↓ (8/13)

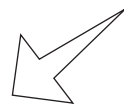

15

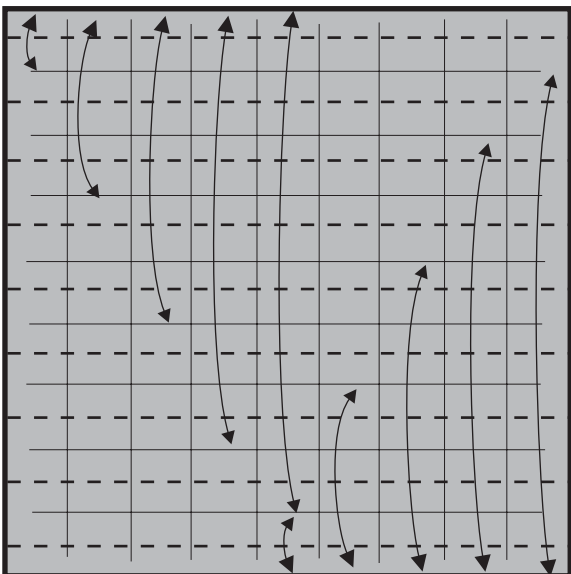

16

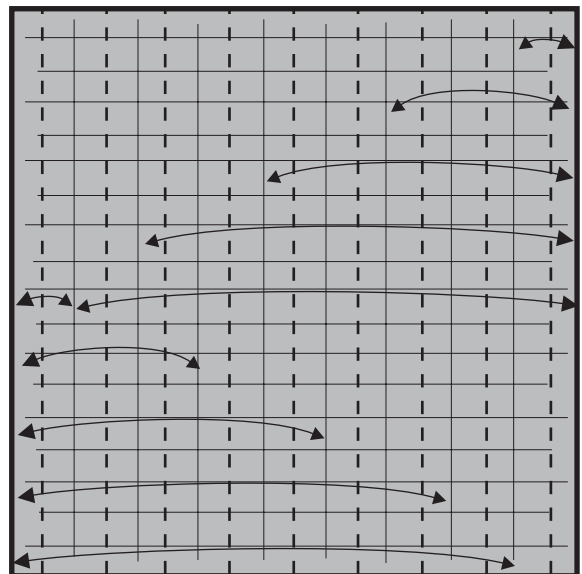

17

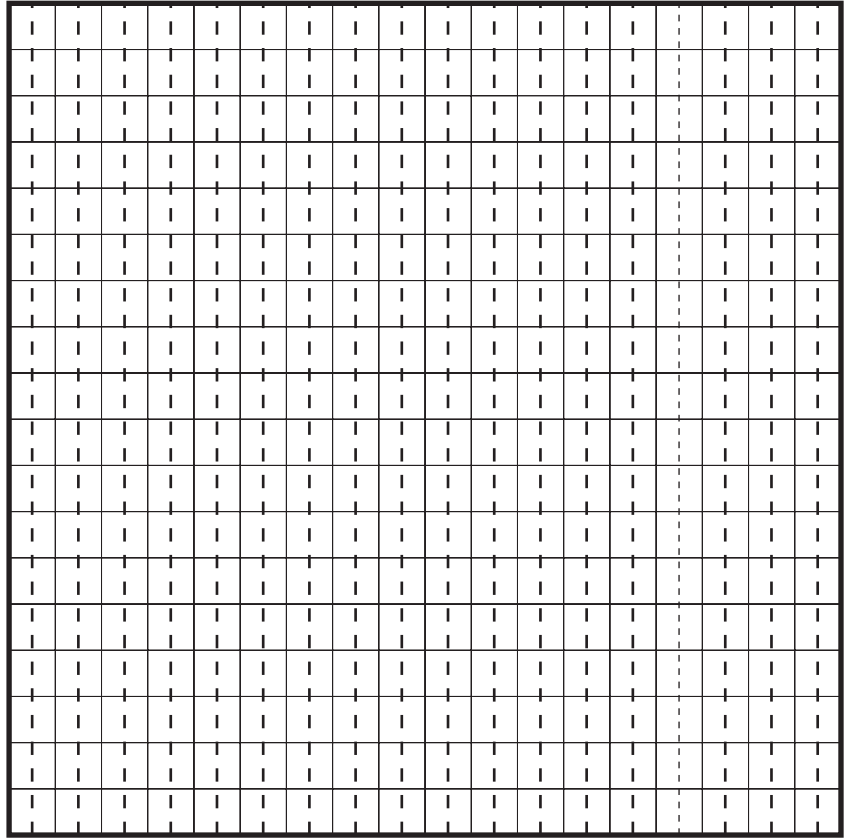
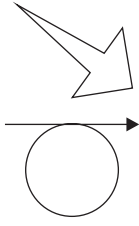

18

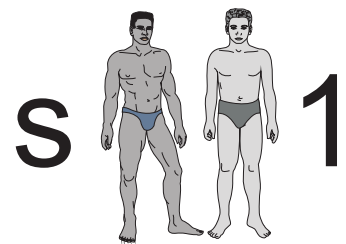
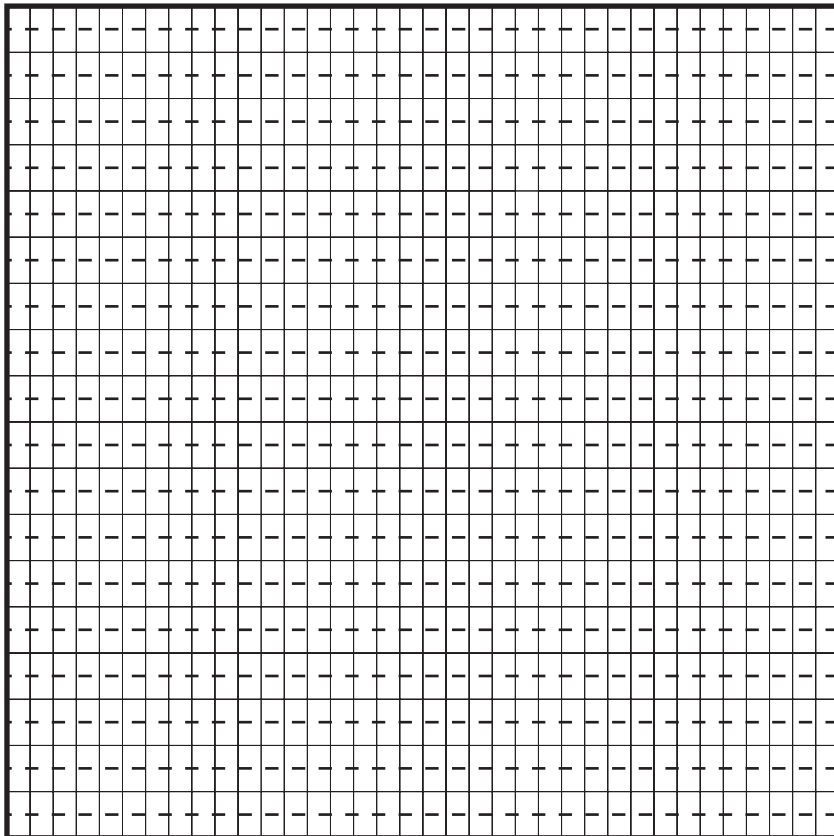

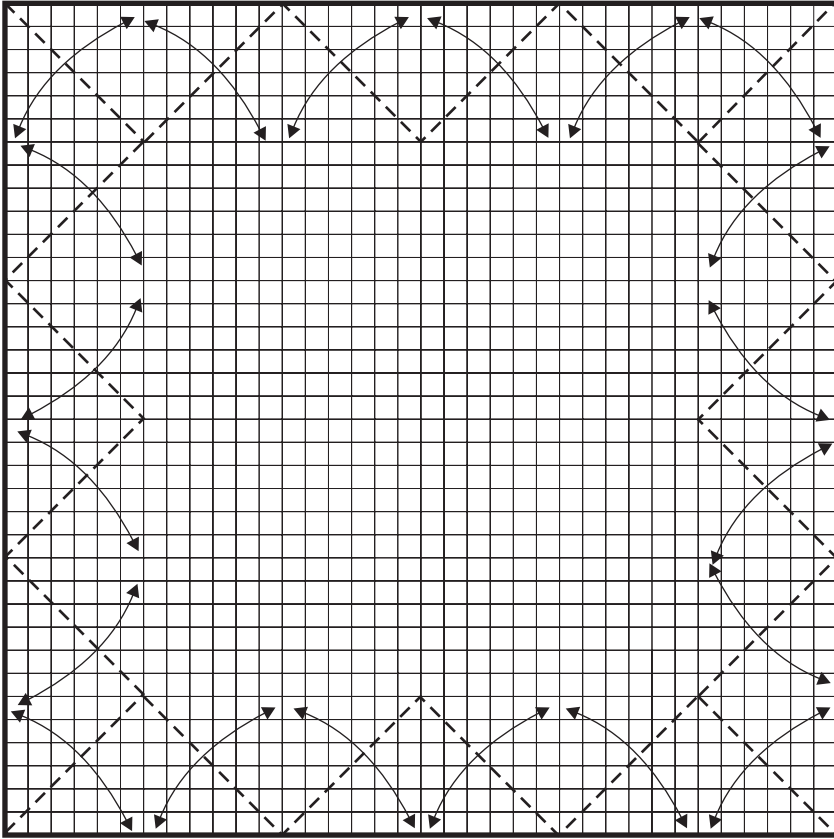

19

20

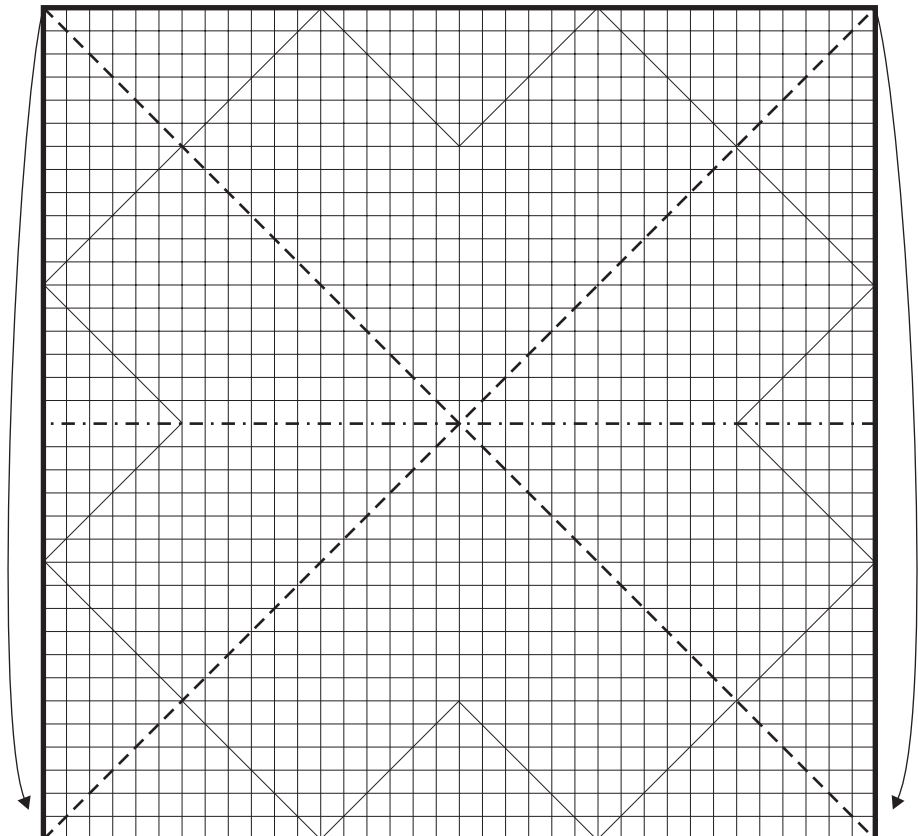

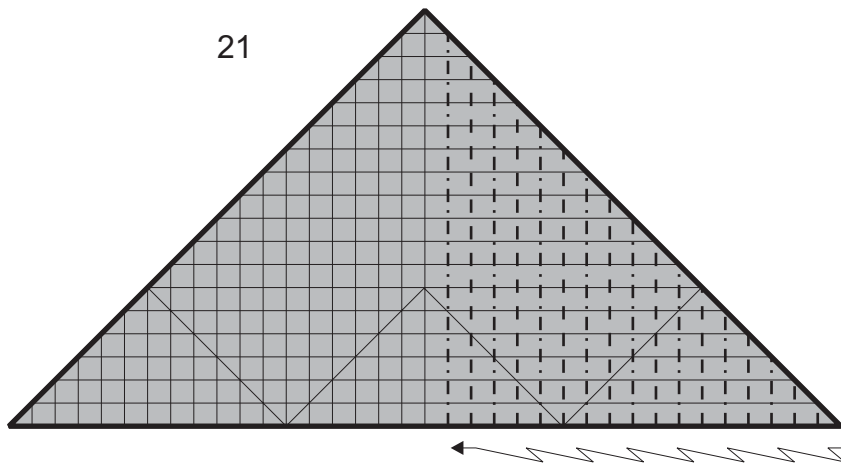

23 aprire uno dei quattro angoli, quel tanto da poter lavorare

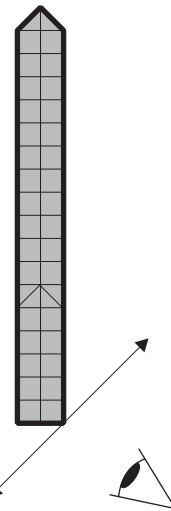
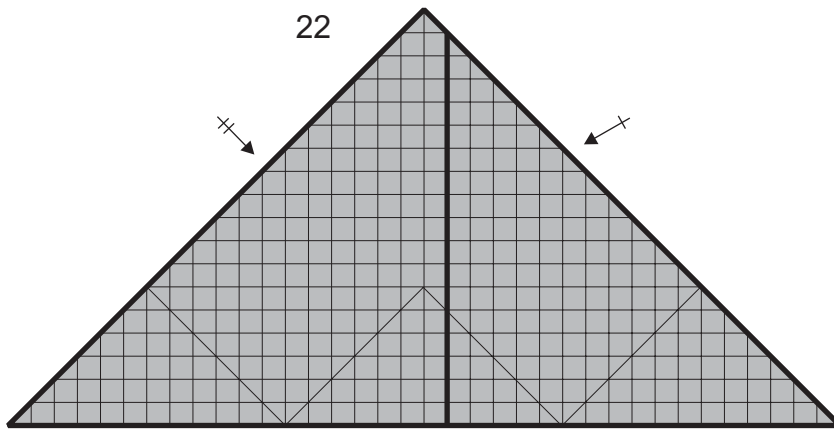

24 per semplificare ho disegnato solo l'angolo che dobbiamo modificare

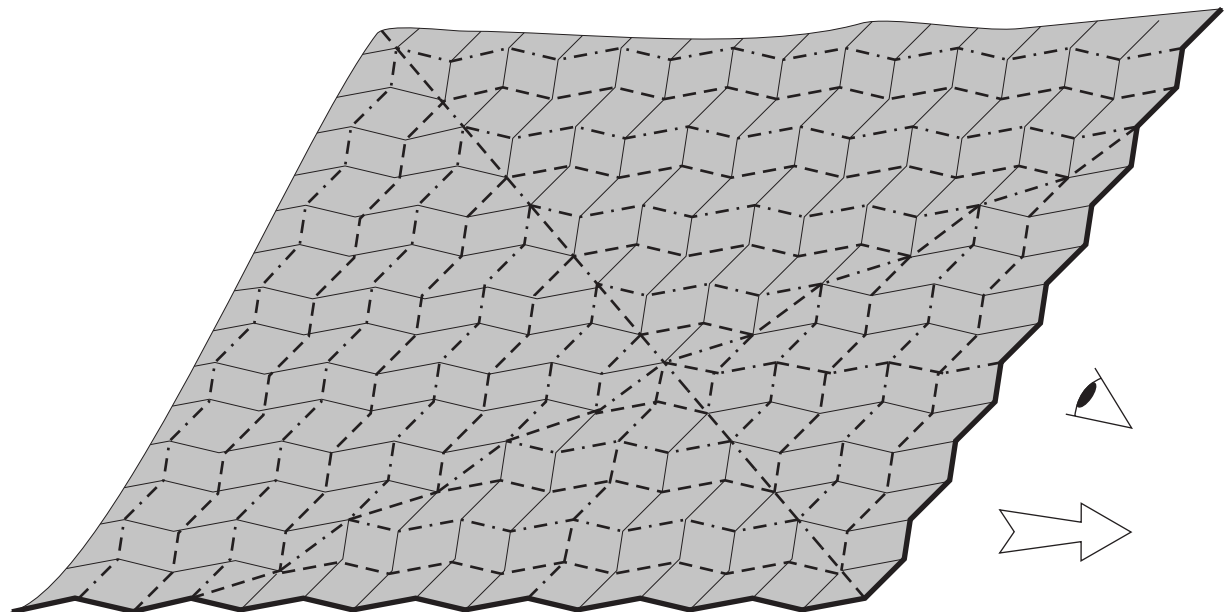

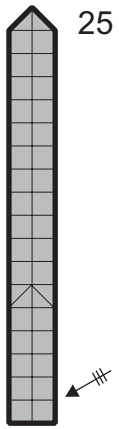

25

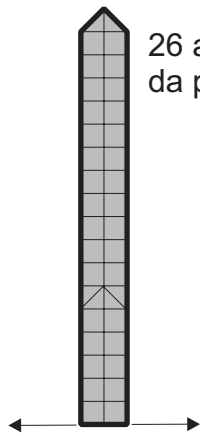

26 aprire quel tanto da poter lavorare

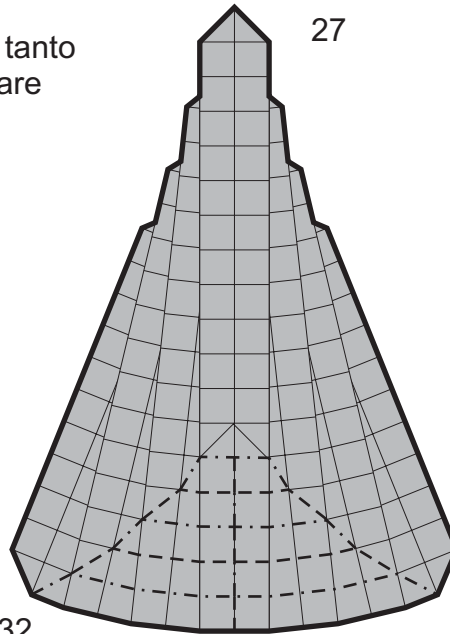
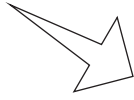

27

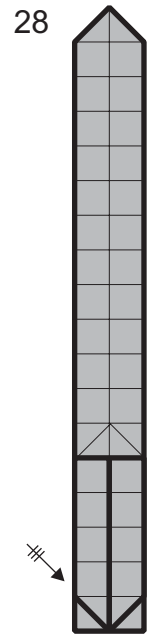

28

29 estrarre il triangolo interno

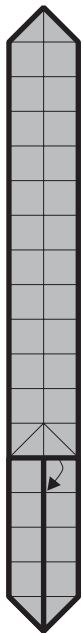

30

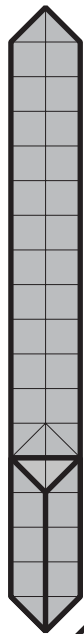

31

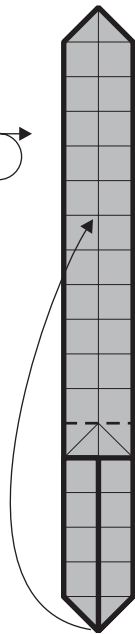

32



33

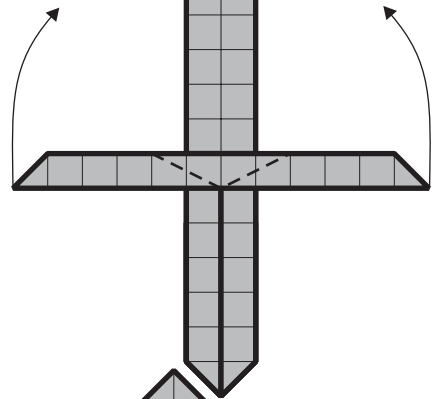

34

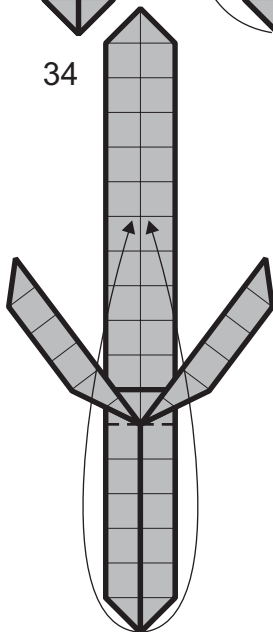

35

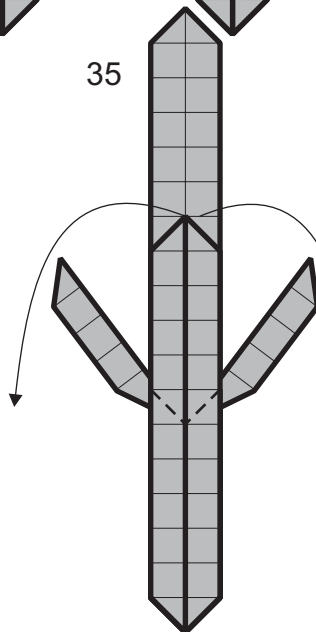

36

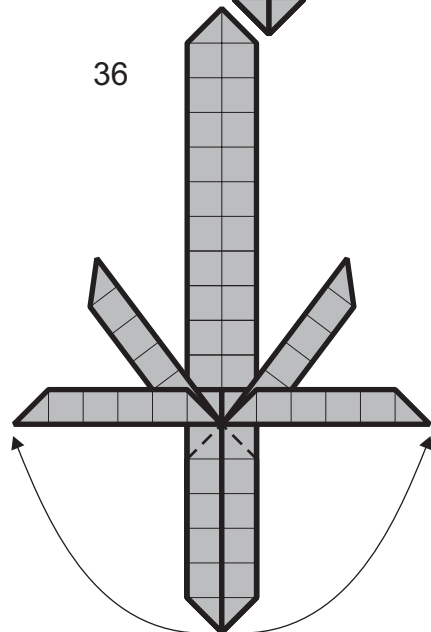

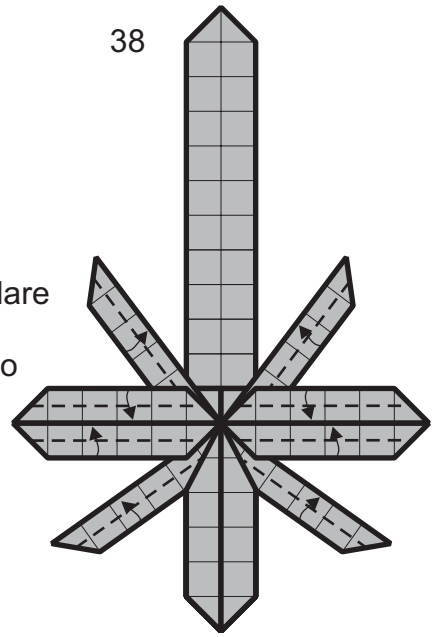
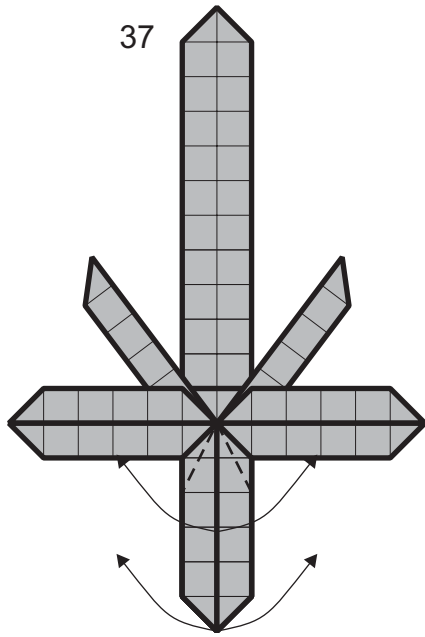

39 modellare le chele guardando una foto

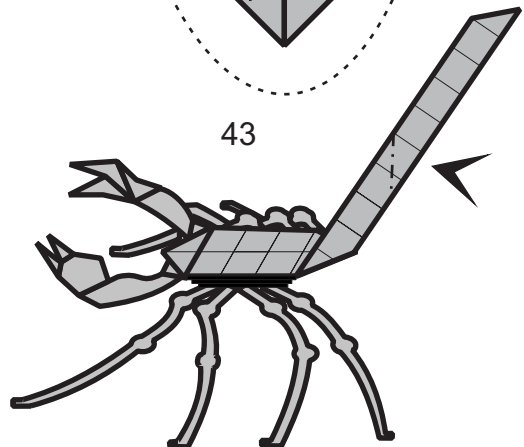
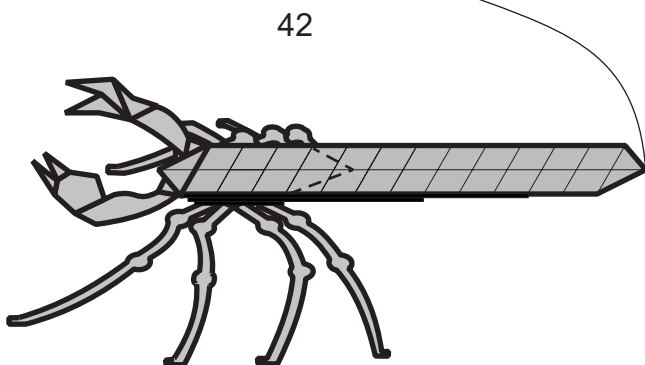
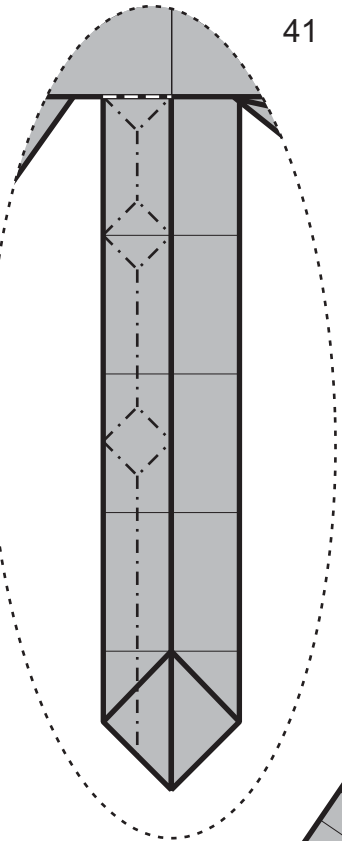
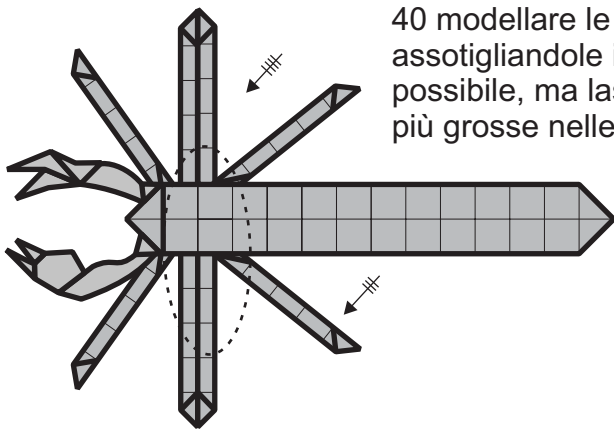
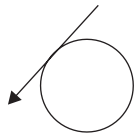
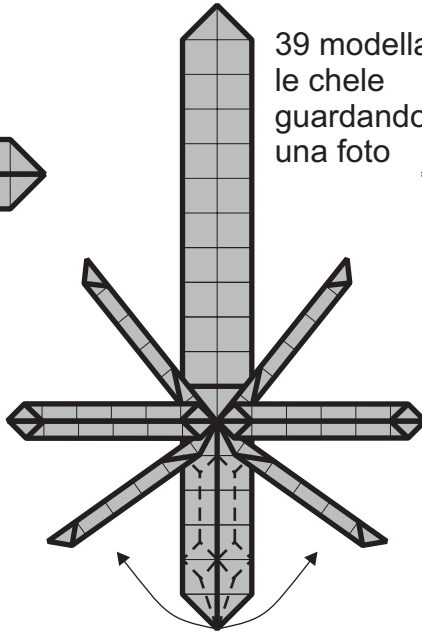

44 infilare una matita, dare spessore e modellare il corpo.

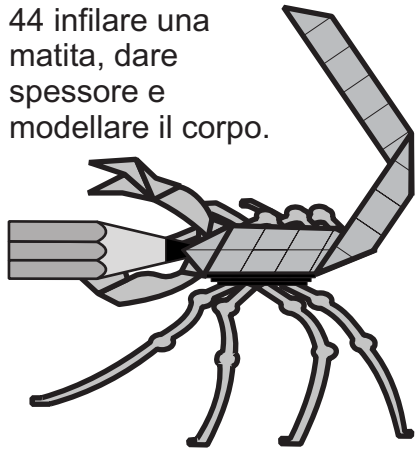

45

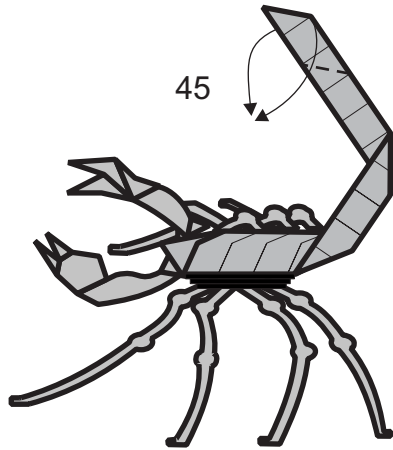

46

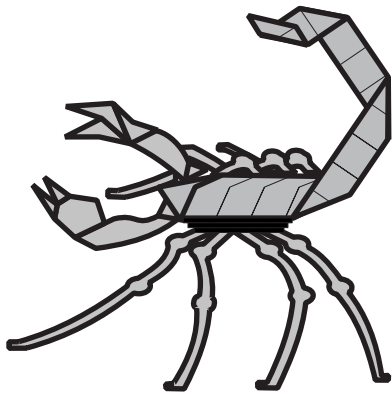
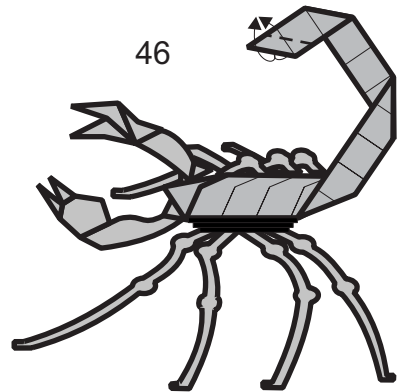

47 ultimare il modello modellando la coda e equilibrando tutto il corpo

48

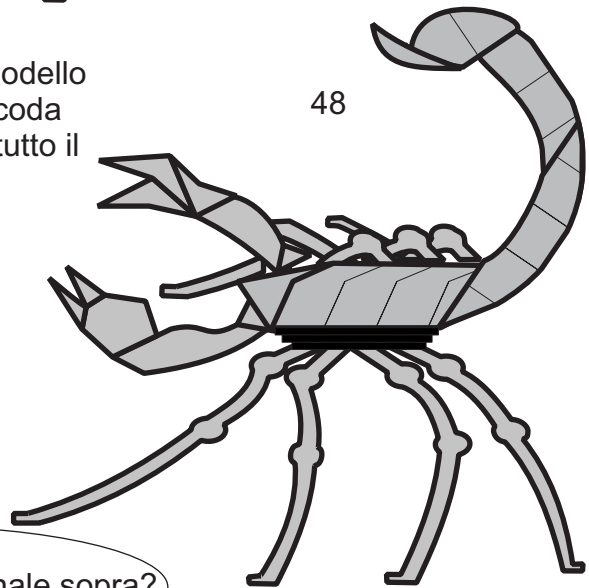

mi ha punto uno scorpione

ci hai messo del medicinale sopra?

no, è scappato subito

