

Pesisto di P. D'Auria

<http://www.origamidauria.it>

per questo modello e
consigliabile un foglio
di carta metallizzata
di grande dimensione.

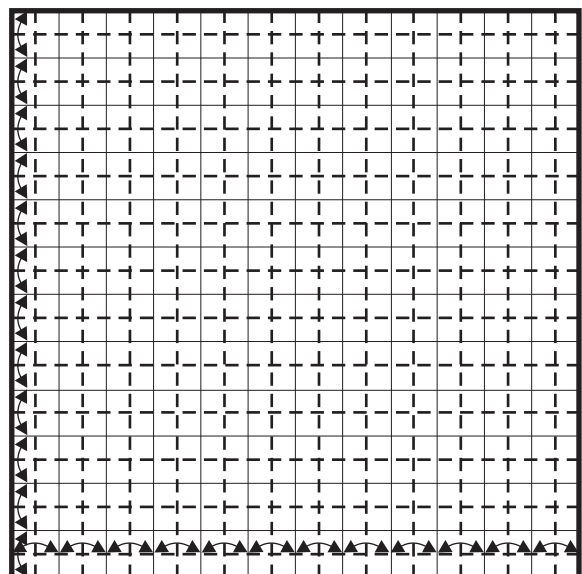
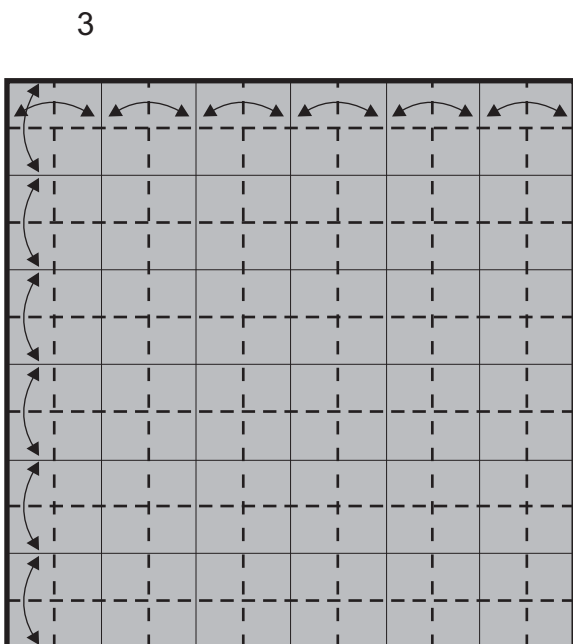
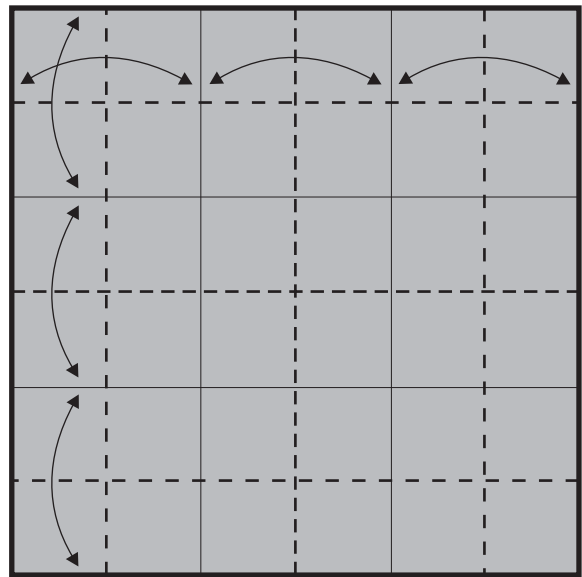
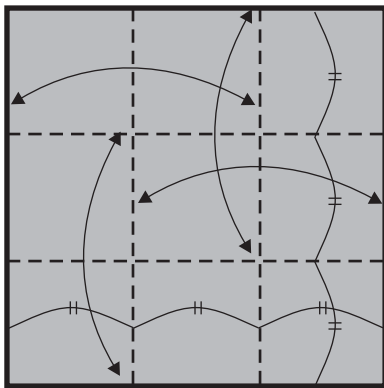
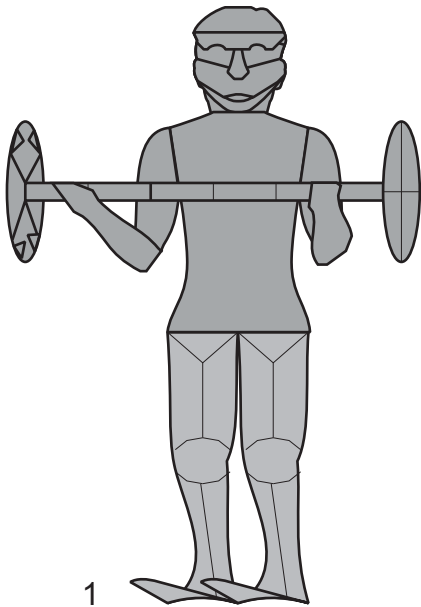
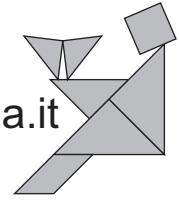

5

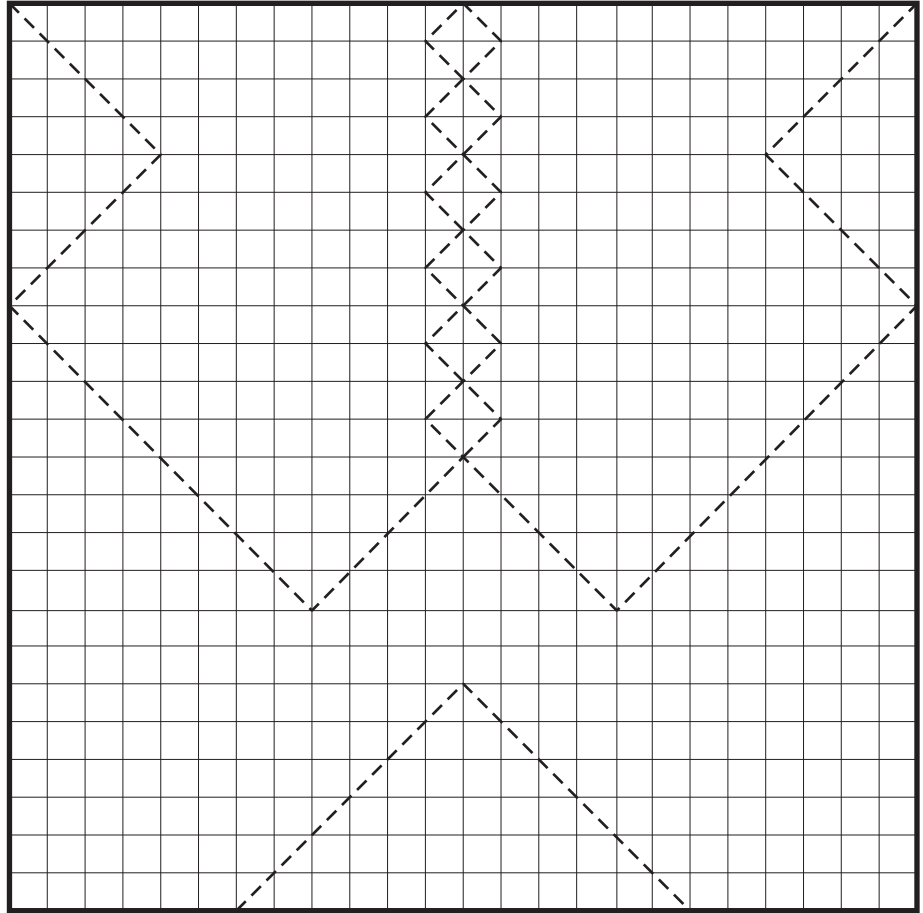

6

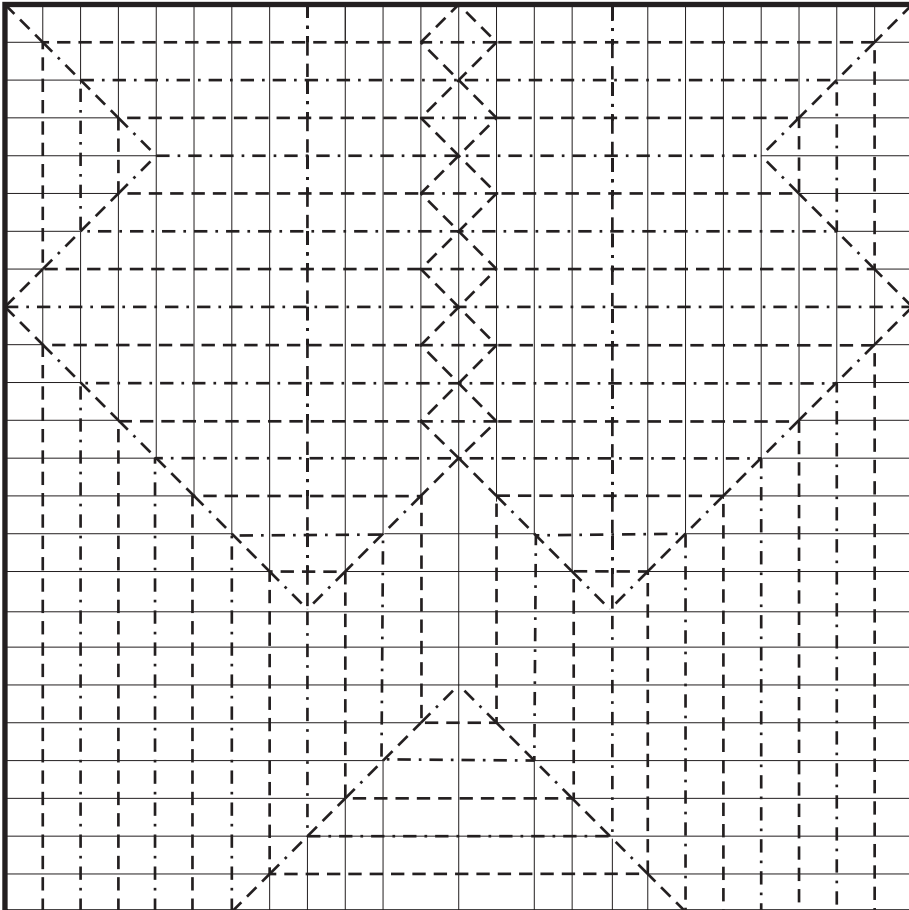

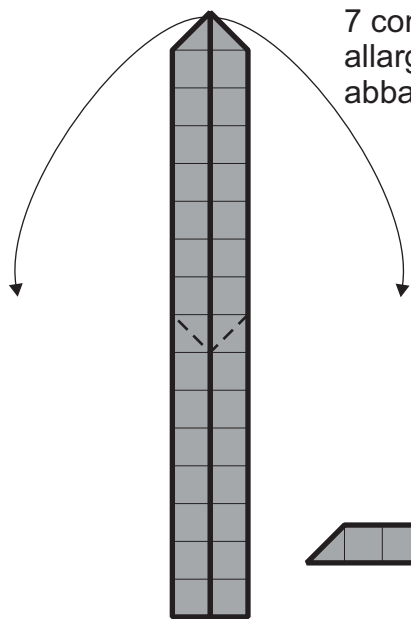

7 con una sola manovra,
allargare le braccia e
abbassare la testa

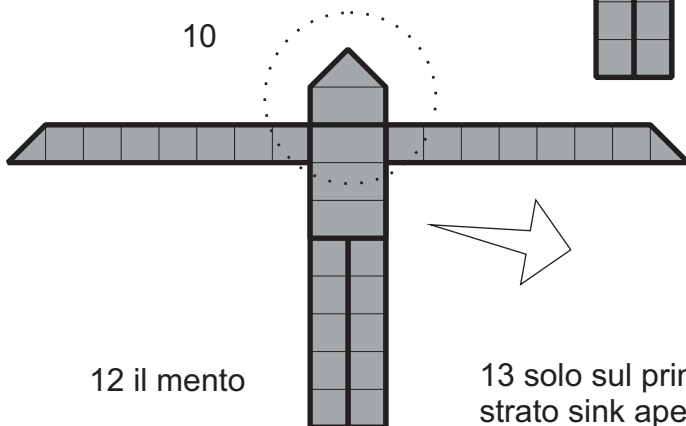
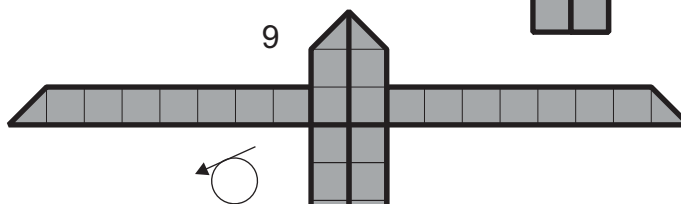
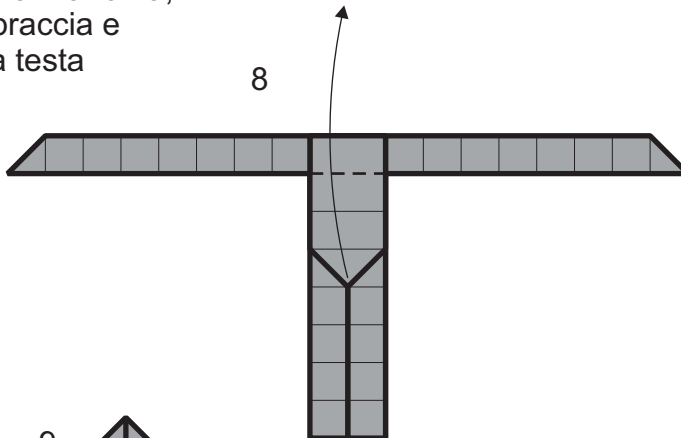

11 abbassare il primo strato

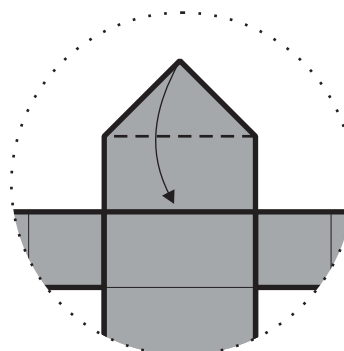

12 il mento

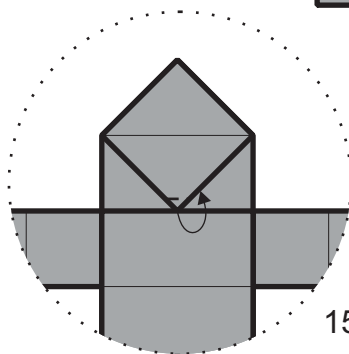

13 solo sul primo
strato sink aperto

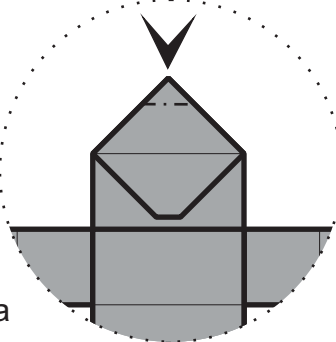

15 bocca

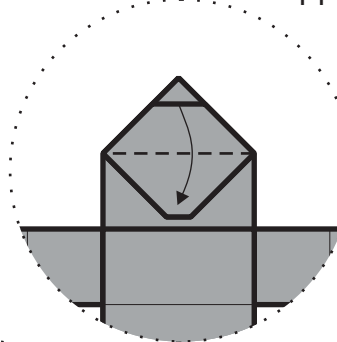
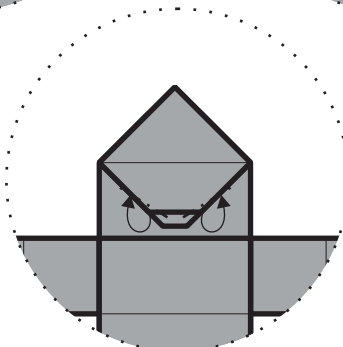

14

16 solo sul
primo strato

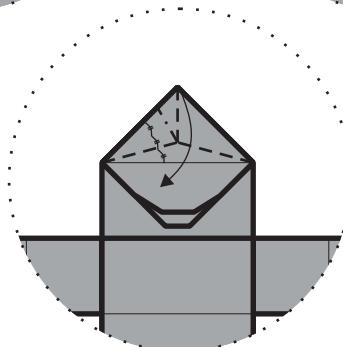

17 naso

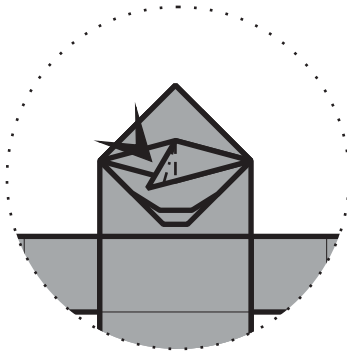

18 solo sul primo strato

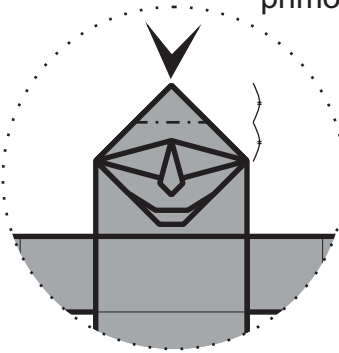

19

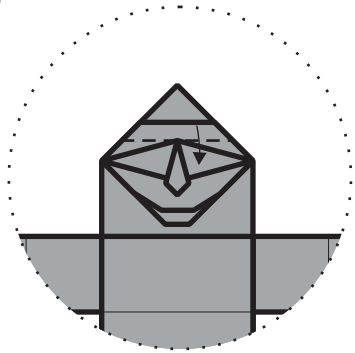

20 tutti gli strati

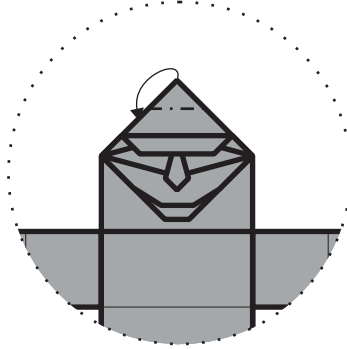

21 modellare bocca naso e occhi

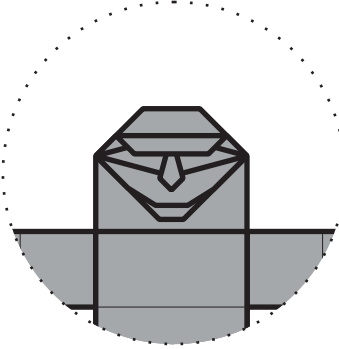

22

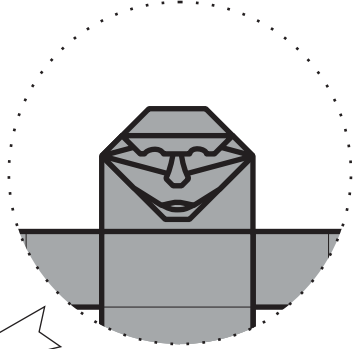

23 le linee sono più sottili per evidenziare i particolari

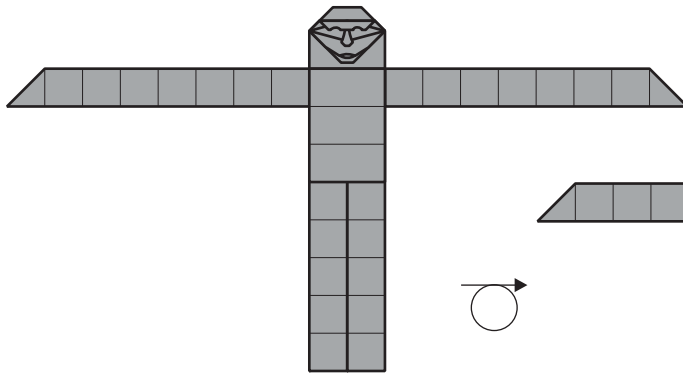

24

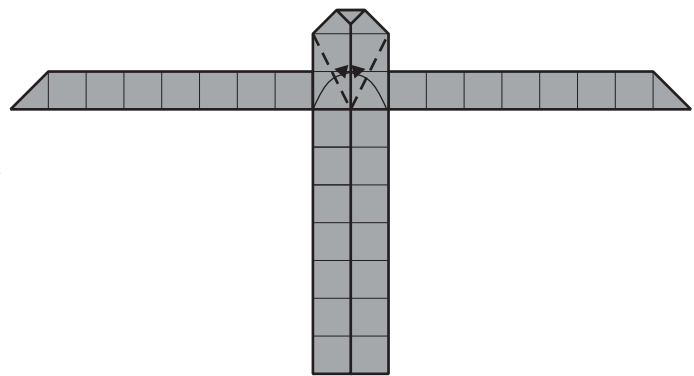

25

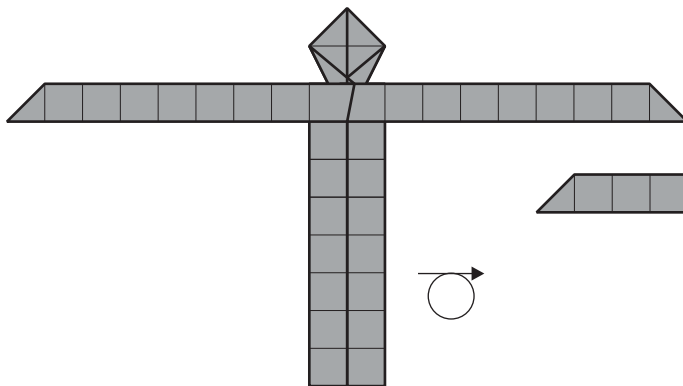

26 modellare il volto



27

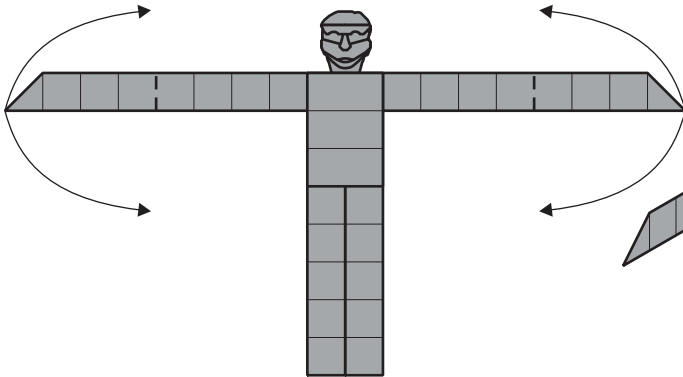

28

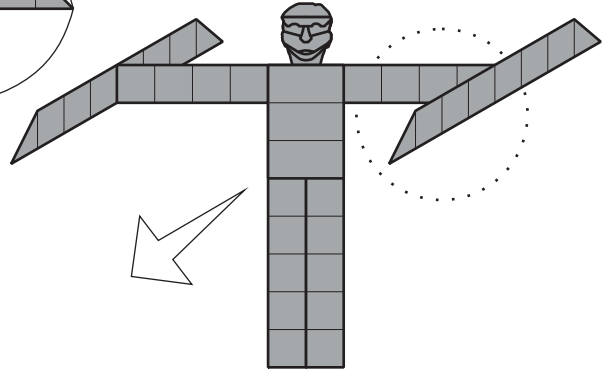

29 aprire quanto basta per poter lavorare

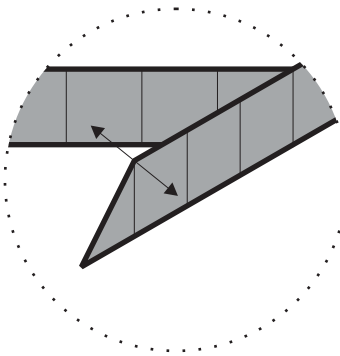

30 estrarre gli strati interni e creare la figura successiva

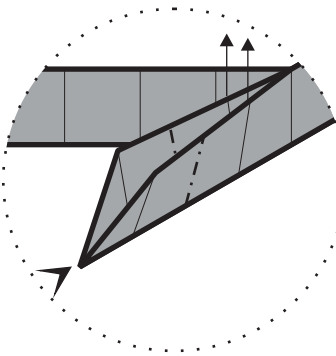

31 con queste pieghe rimettiamo dentro lo strato che avevamo estratto

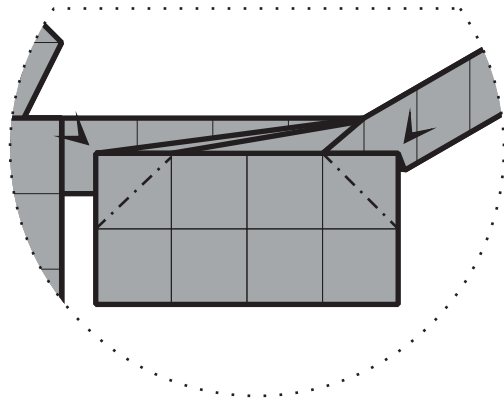

32 per fare queste pieghe dobbiamo schiacciare gli strati nascosti

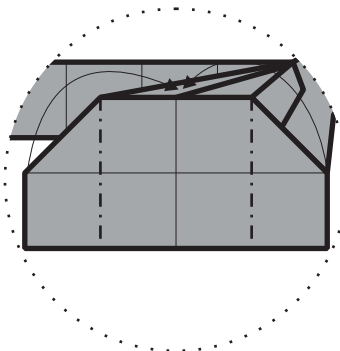

33

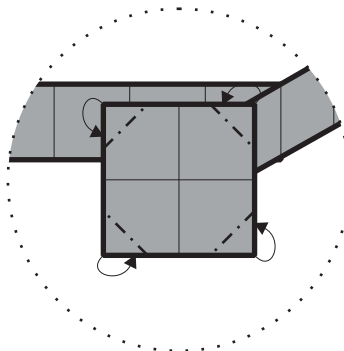

34 rendere il più possibile simile ad un cerchio

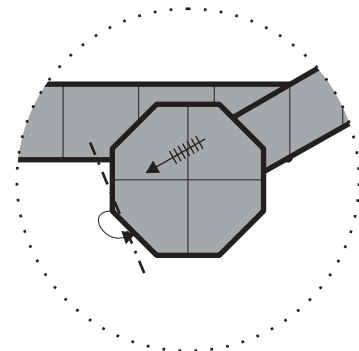

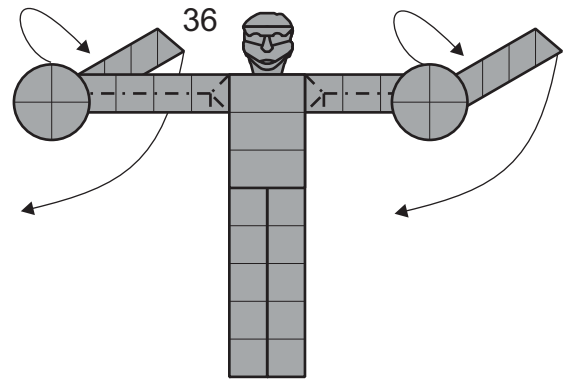
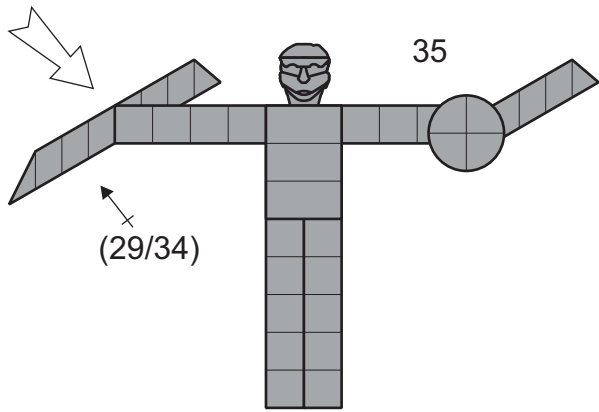

37 aprire quanto basta per poter lavorare

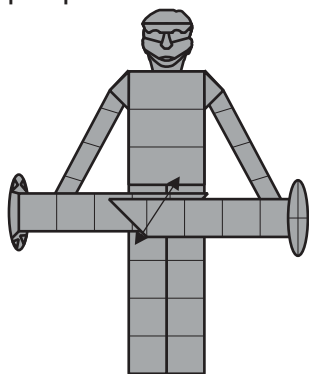

38

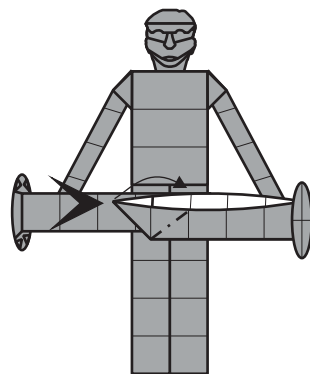

39

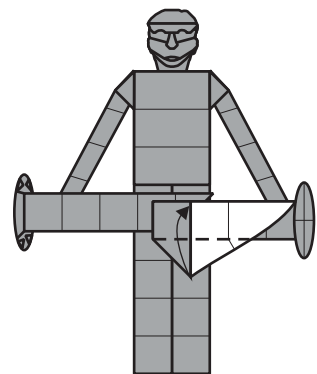

40 mettere dietro

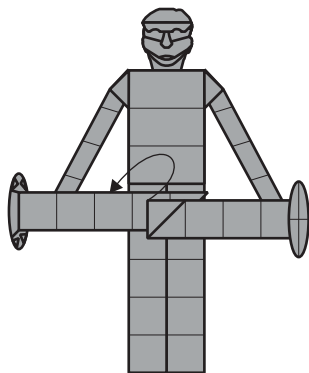

41

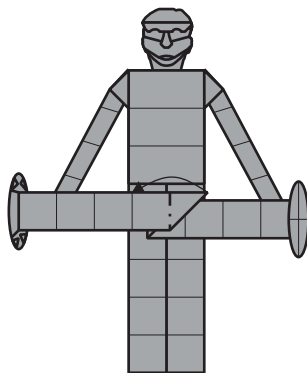

42 infilare e incastrare

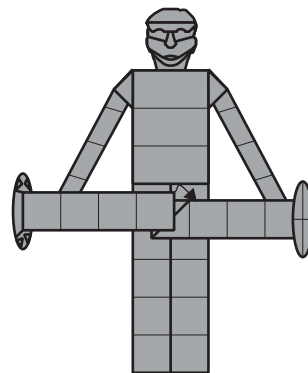

43

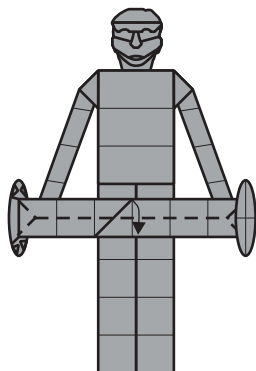

44 rendere il più possibile simile ad una sbarra

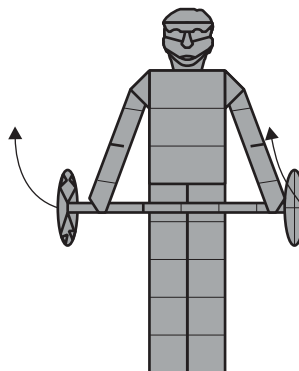
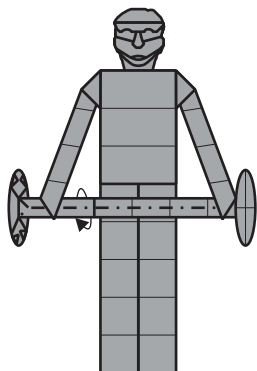

45 pieghiamo i gomiti, per alzare ed allontanare il bilanciere dal corpo, ricordiamoci che è un gomito, quindi una piega morbida.

46

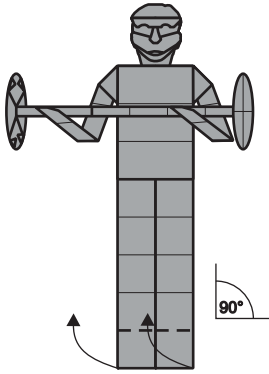

47 modellare i piedi

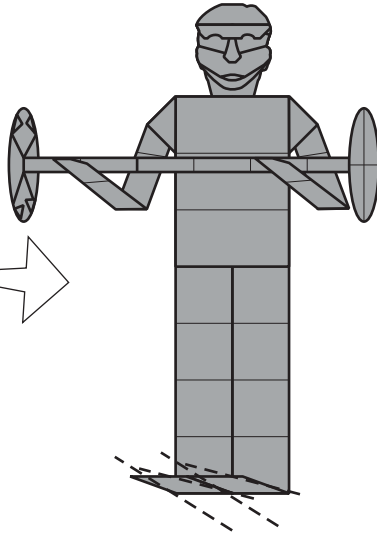

48 queste non sono vere pieghe, ma sono un modellare la carta.

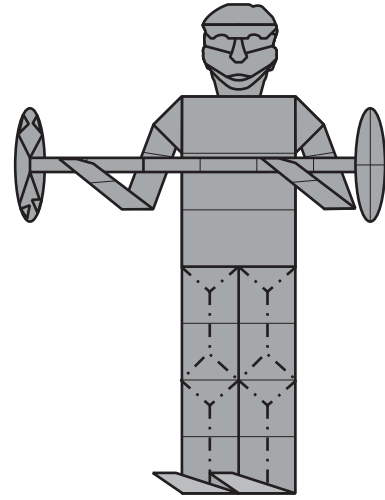

49 modellare tutto il corpo

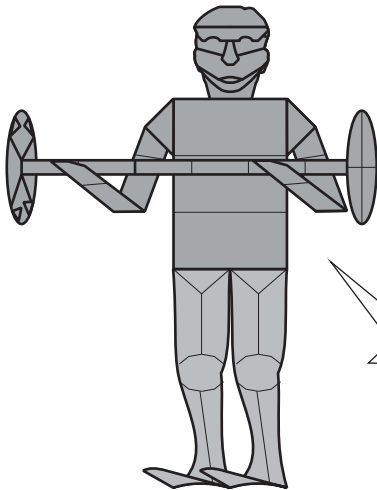

50

se ti faccio cadere il peso addosso, sarà dichiarato «omicidio col peso?»

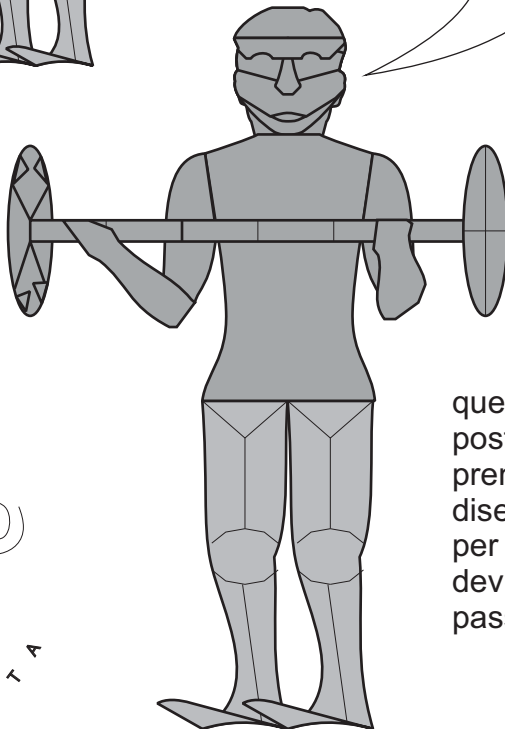

questo modello può assumere diverse posture, per la modellazione finale puoi prendere spunto da fotografie o dai disegni della prossima pagina, per alcune posizioni devi far ruotare le spalle facendo passare i piedi all'interno del bilanciere



