

Merlo shama

di P. D'Auria

<http://digilander.libero.it/origamidauria>

Usare un quadrato nero da un lato e arancione dall'altro.
Partire con il lato arancione in alto.

1

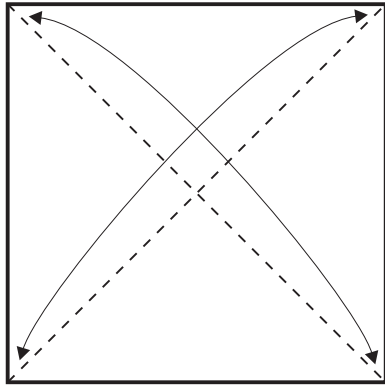

2

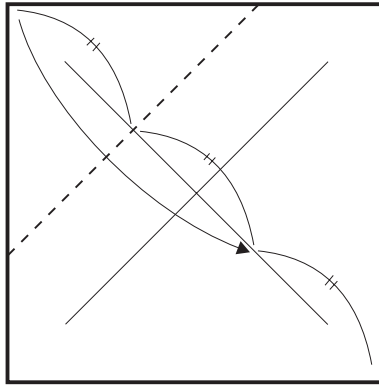

3

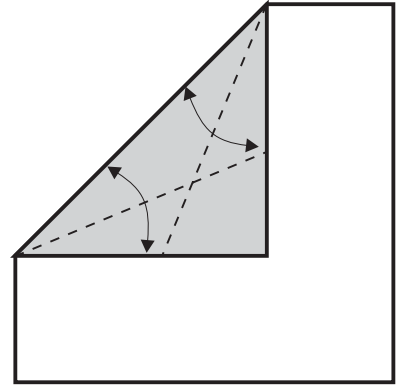

4

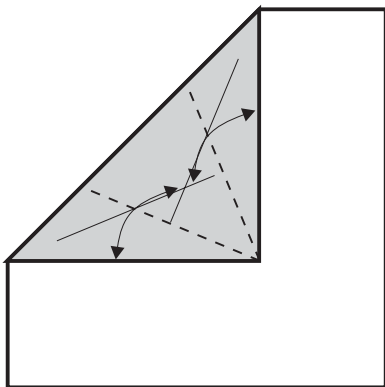

5

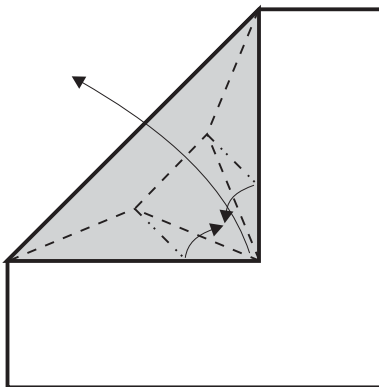

6

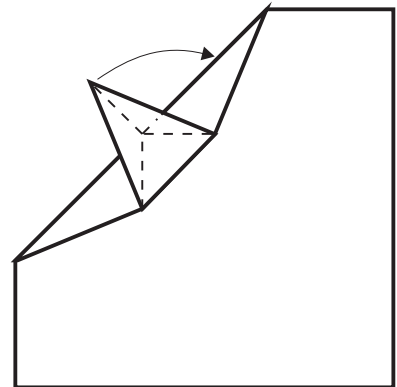

7

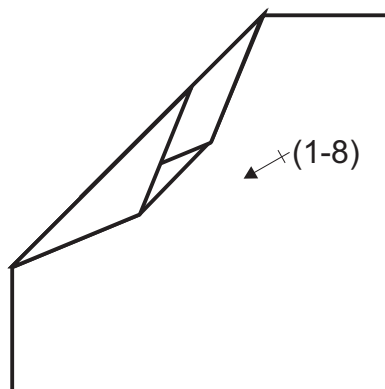

8

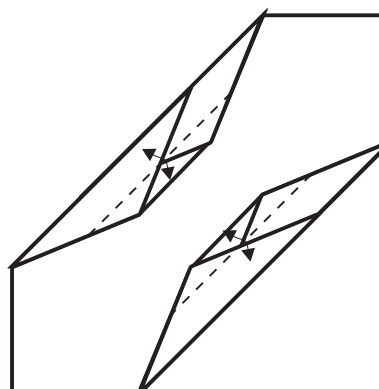

9

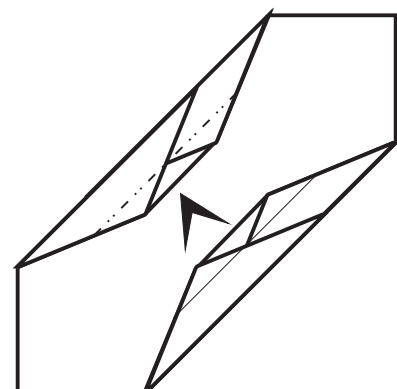

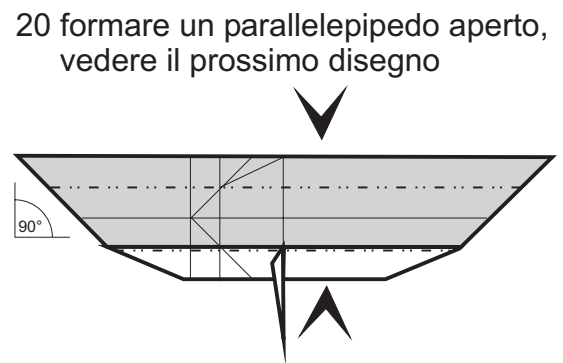
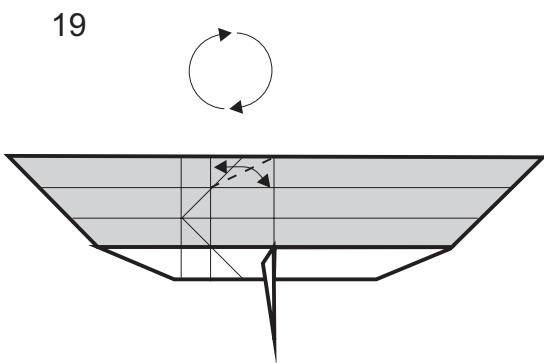
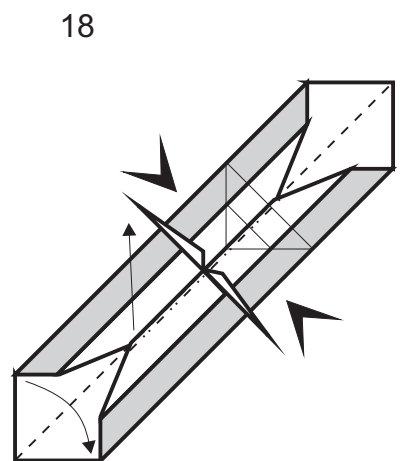
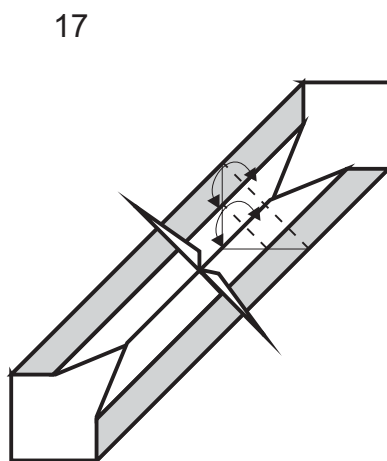
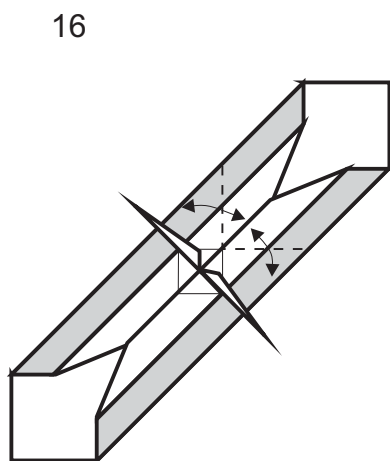
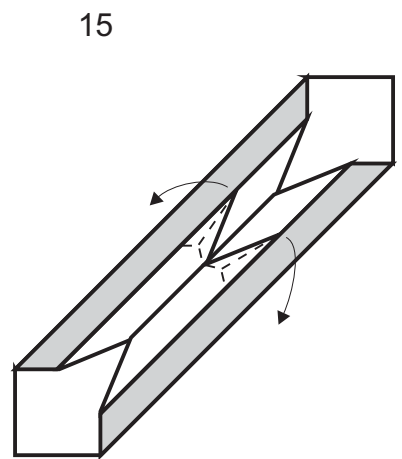
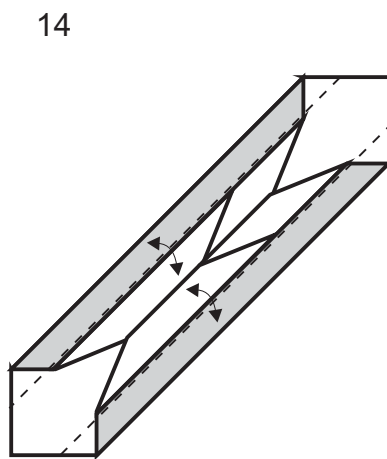
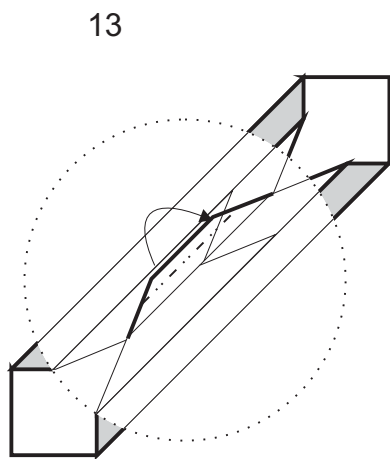
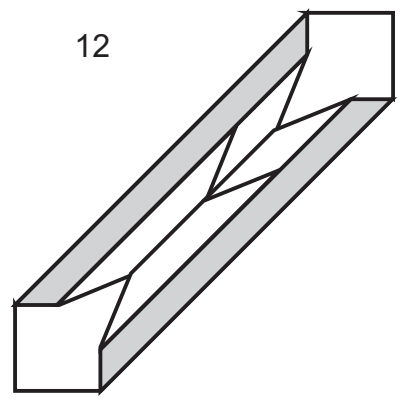
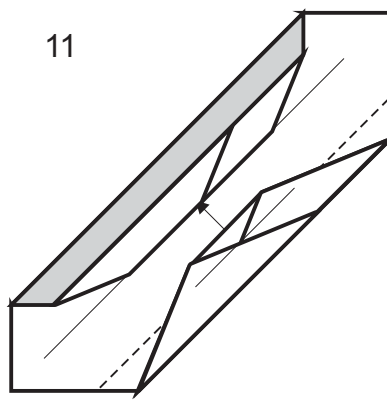
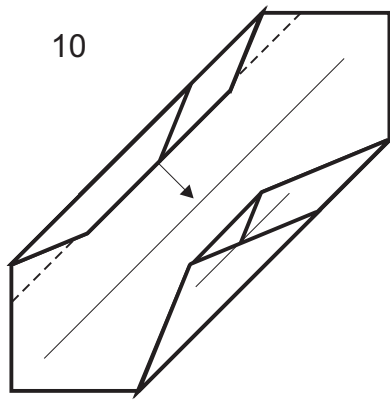

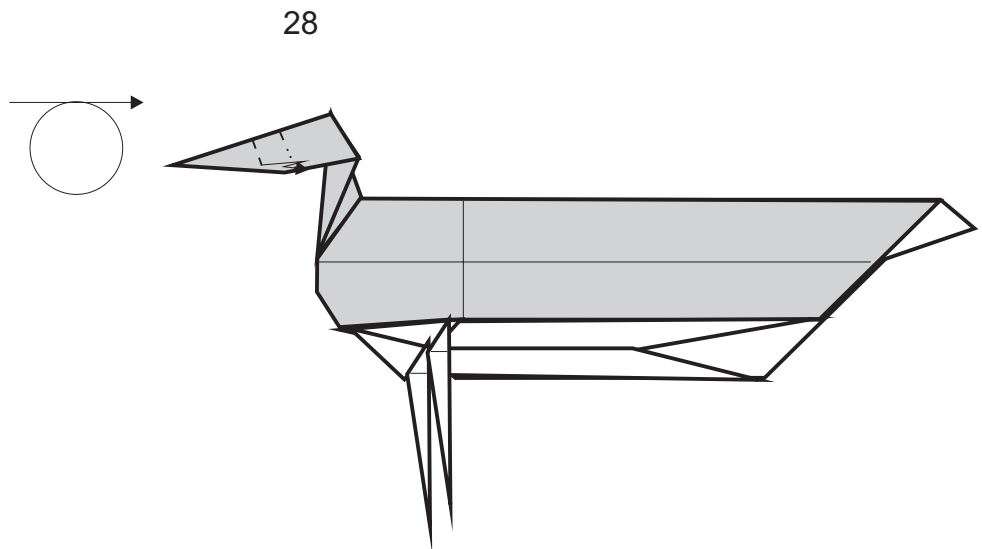
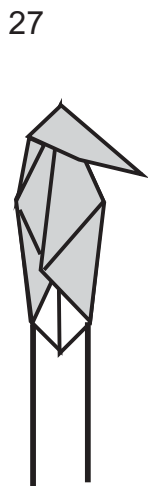
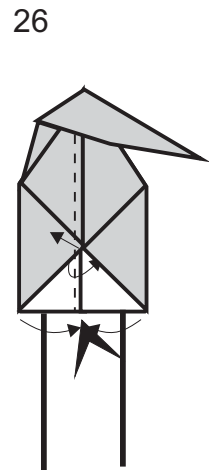
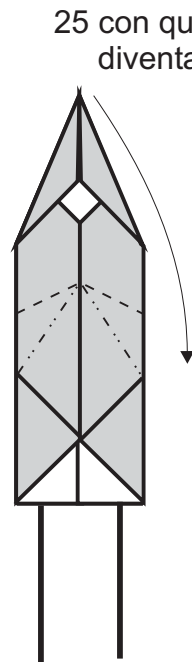
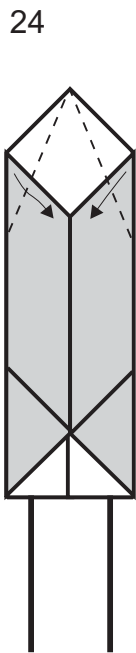
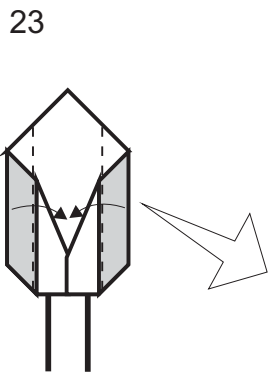
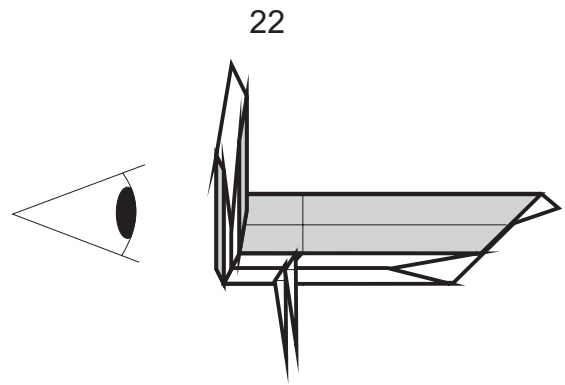
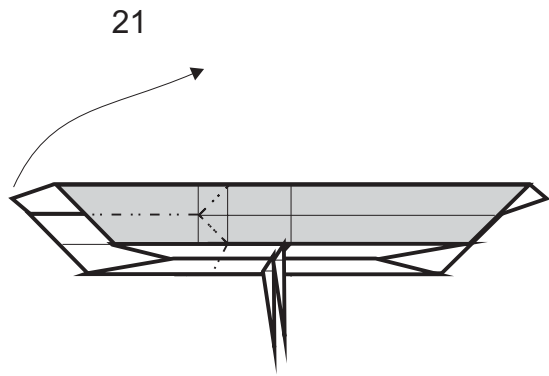

29 usare la carta (schiacciata dalla piega a monte) per avvolgere il corpo come se fossero le ali, e poi riunirla sotto per preparare la coda

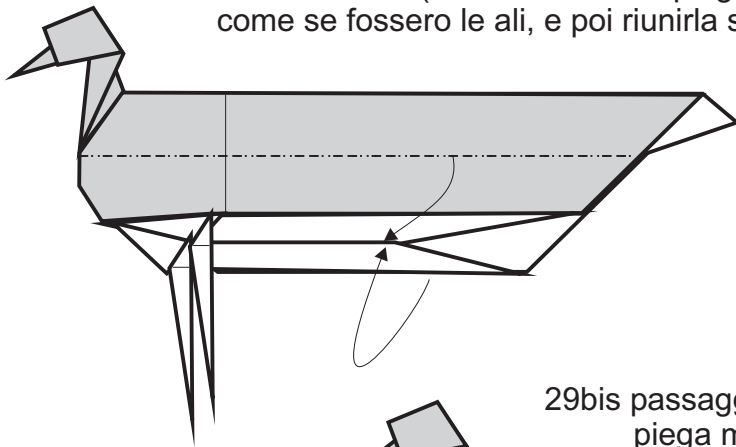

29bis passaggio intermedio di questa piega morbida e tridimensionale

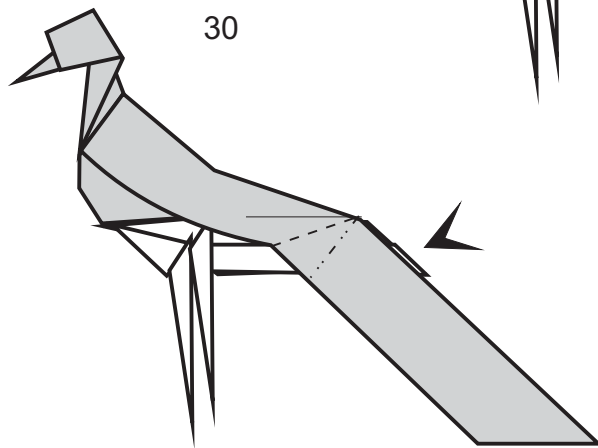
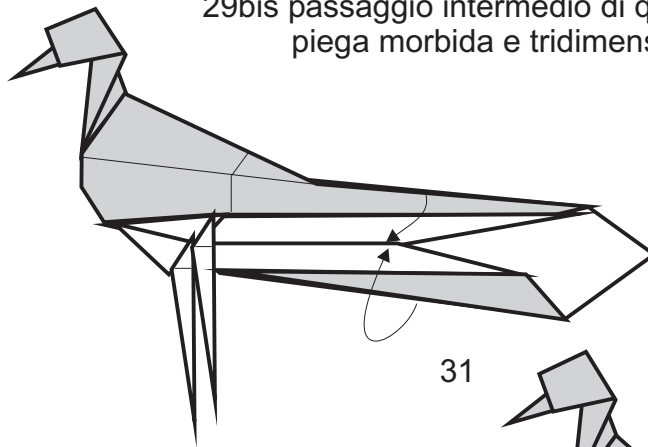

30

31

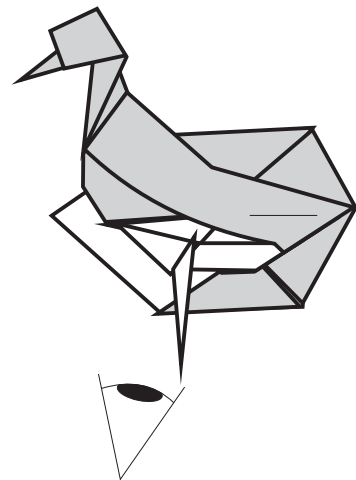

32

33

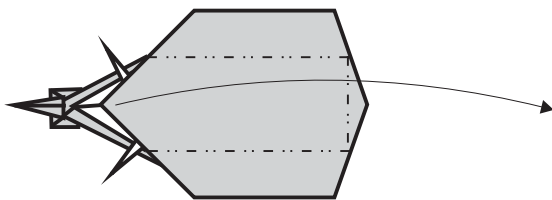

34

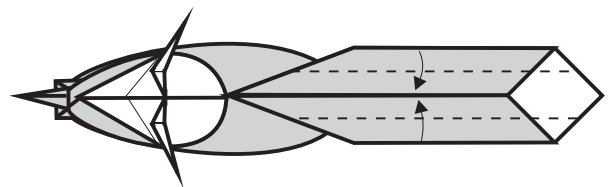

35

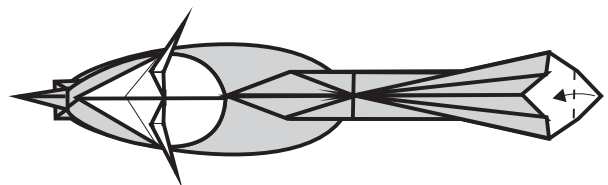
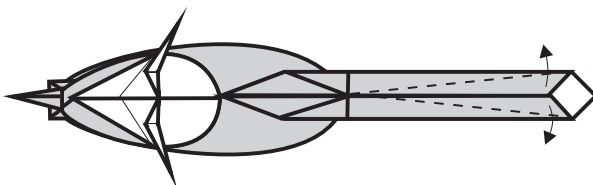

36

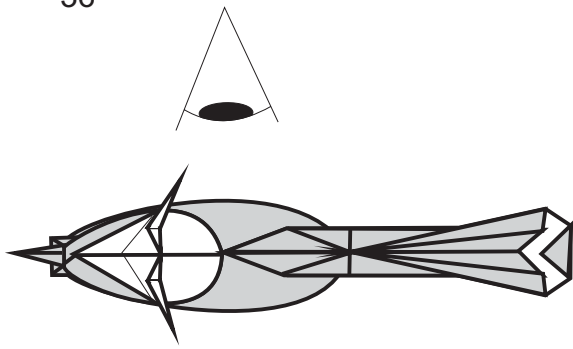

37 notare che creando la coda anche il dorso ha preso una piega più realistica



38 ingrandimento della zampa

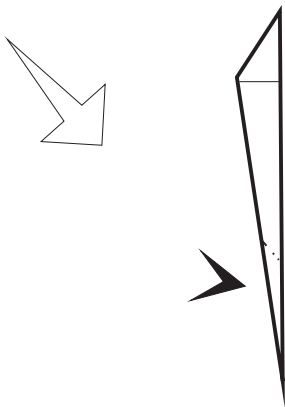

39

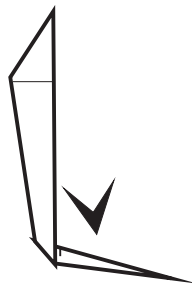

40

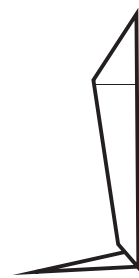

41

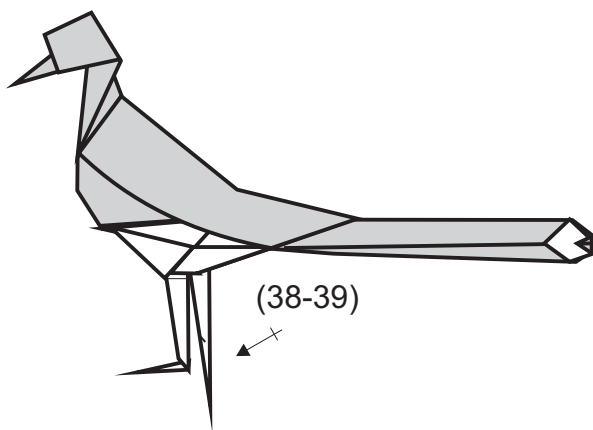

42

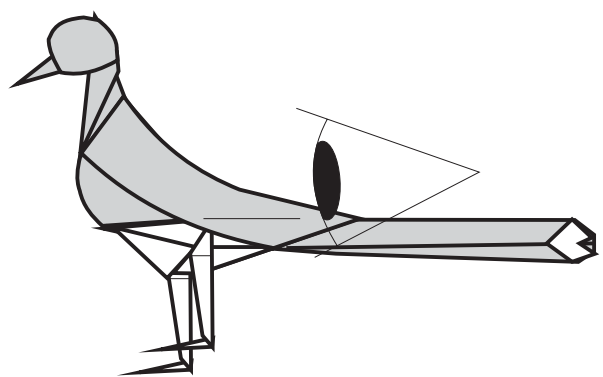

43

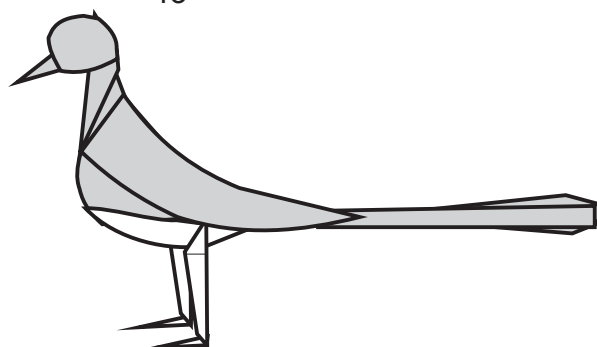

Questo modello l'ho chiamato merlo shama,
ma con poche modifiche può essere qualsiasi
passeraceo:

La carta può essere di diverso colore.

Il becco può variare di grandezza, forma e il
colore può essere invertito.

La coda può variare la forma e la grandezza.

Inoltre si può modificare anche il collo e la testa,
infine potete fare tutte le modifiche che vi consiglia
la vostra fantasia.

