

Lucertola di P. D'Auria

<http://www.origamidauria.it>

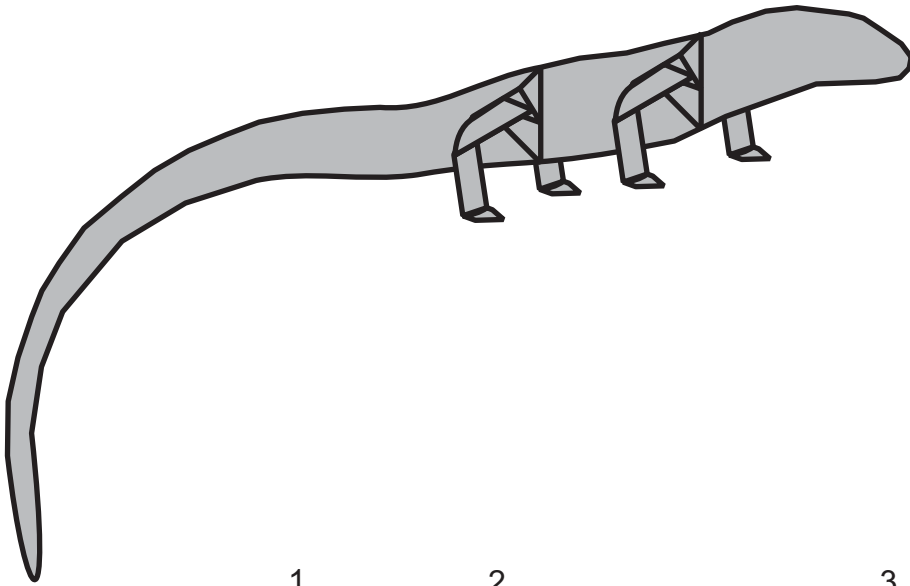

1

2

3

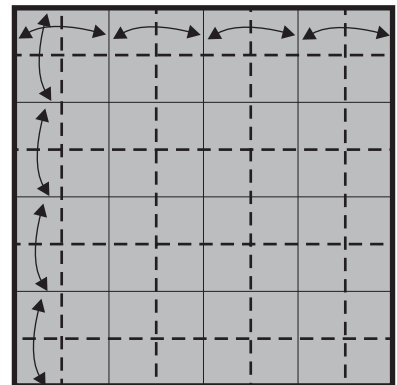
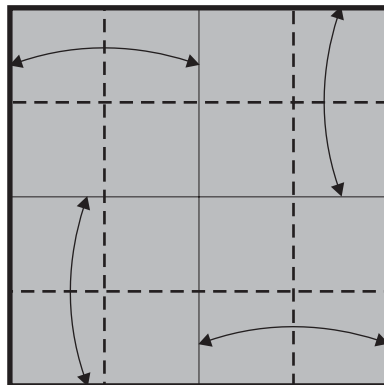
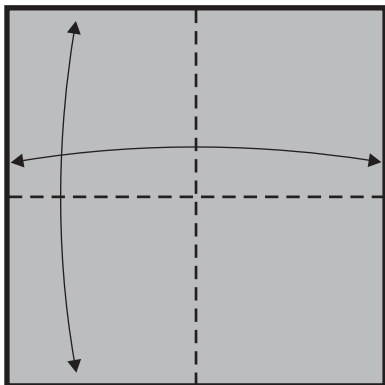

4



5

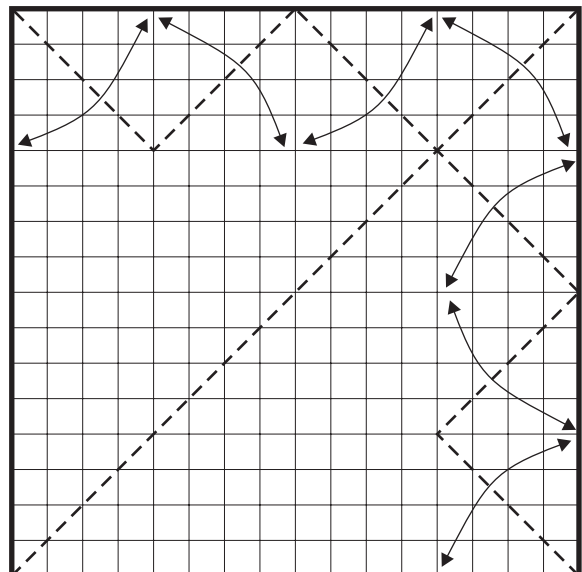
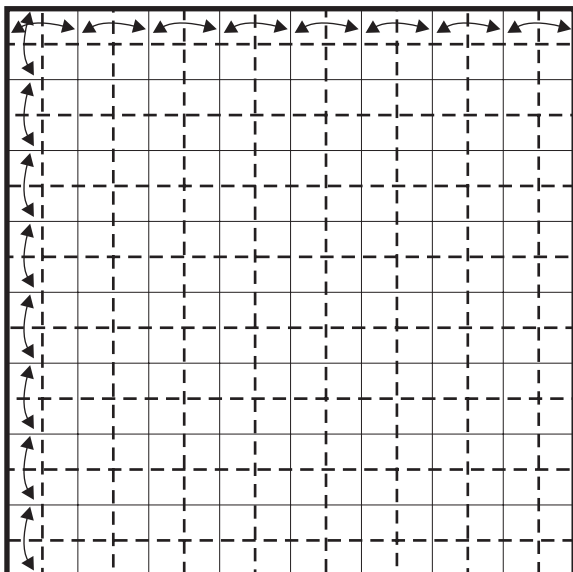

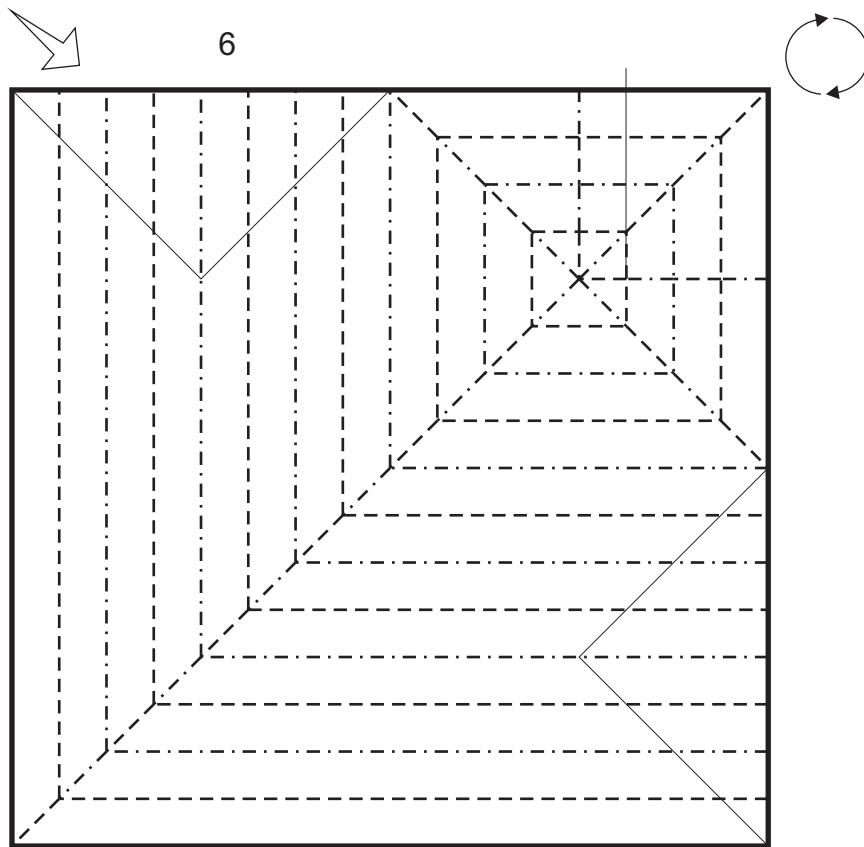

6



7 riaprire solo quanto basta per poter piegare le gambe

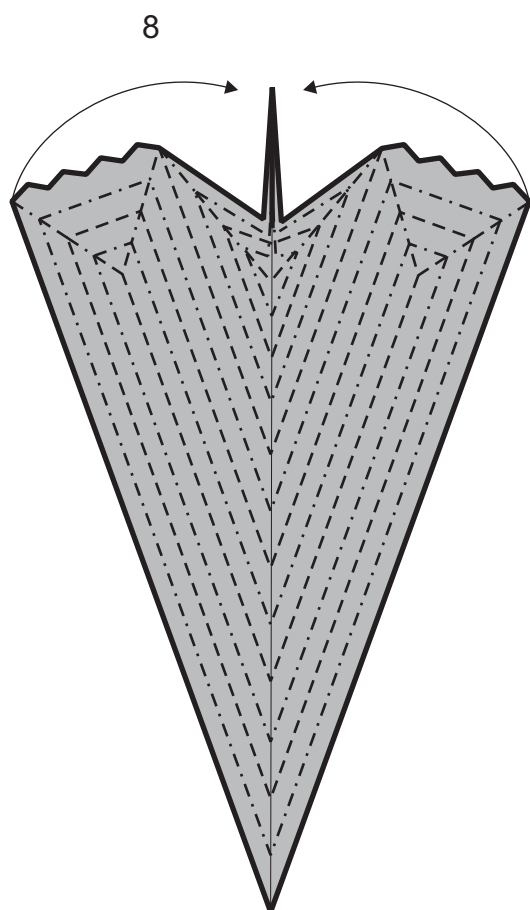

8

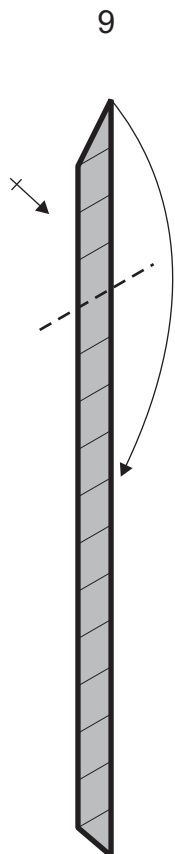

9

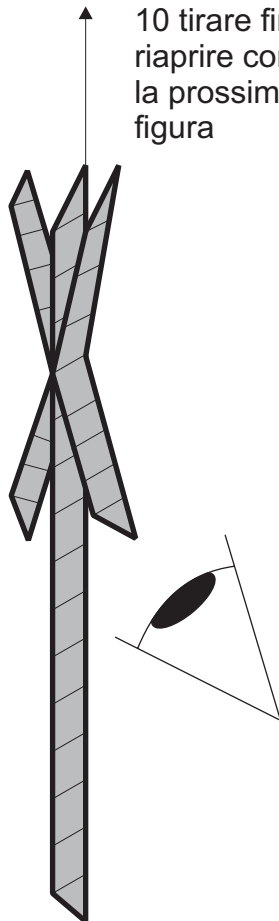

10 tirare fino a riaprire come la prossima figura

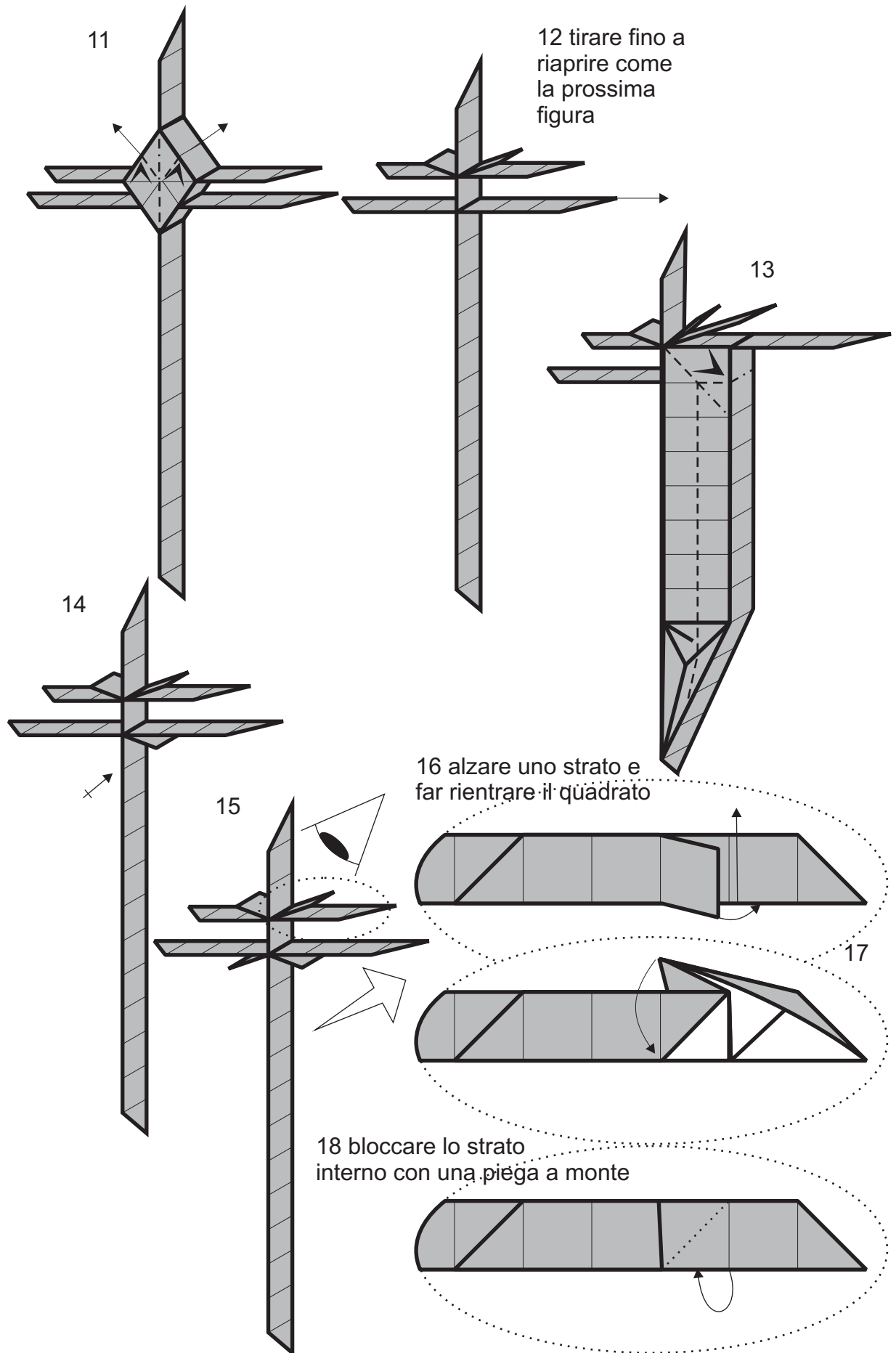

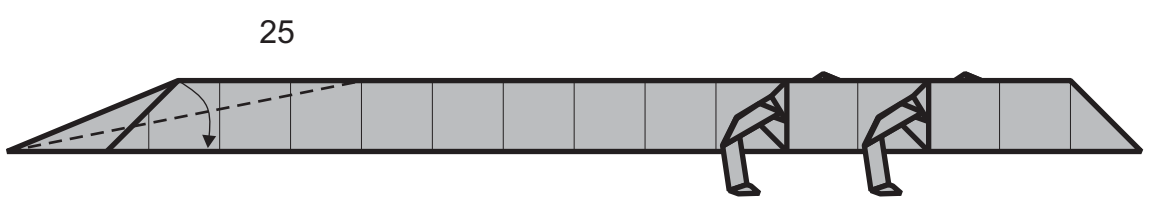
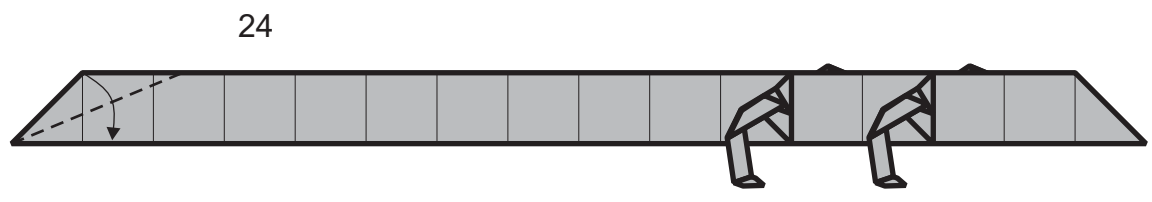
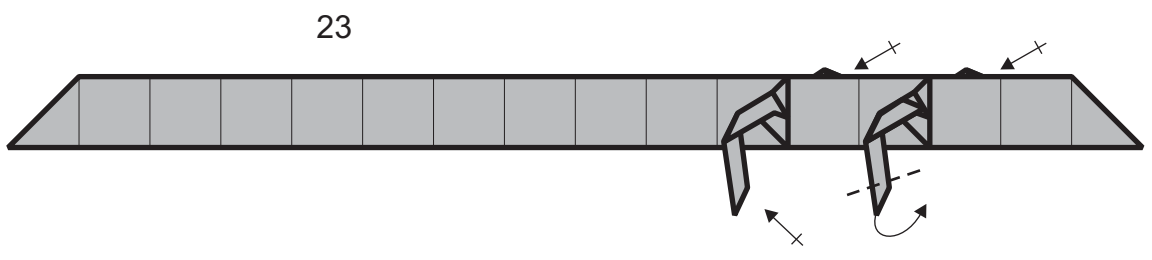
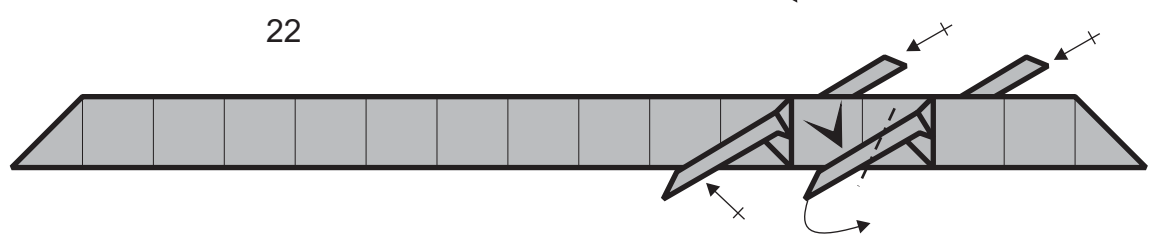
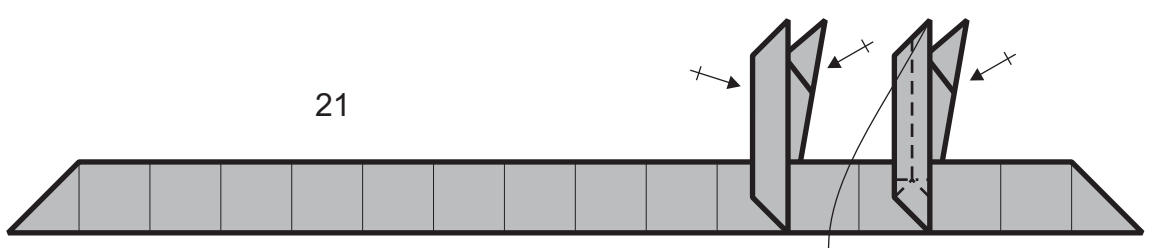
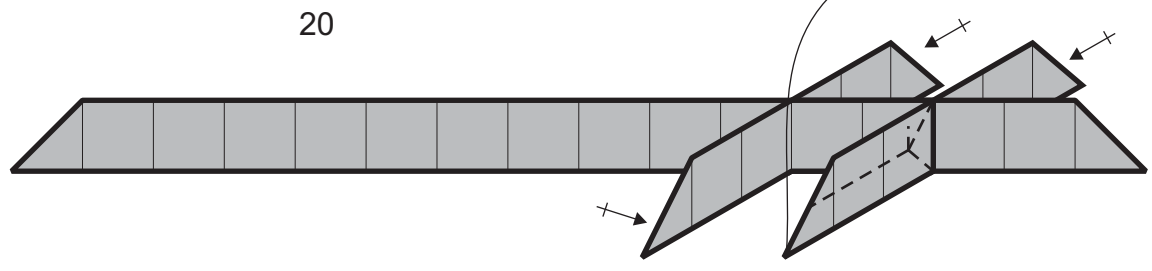
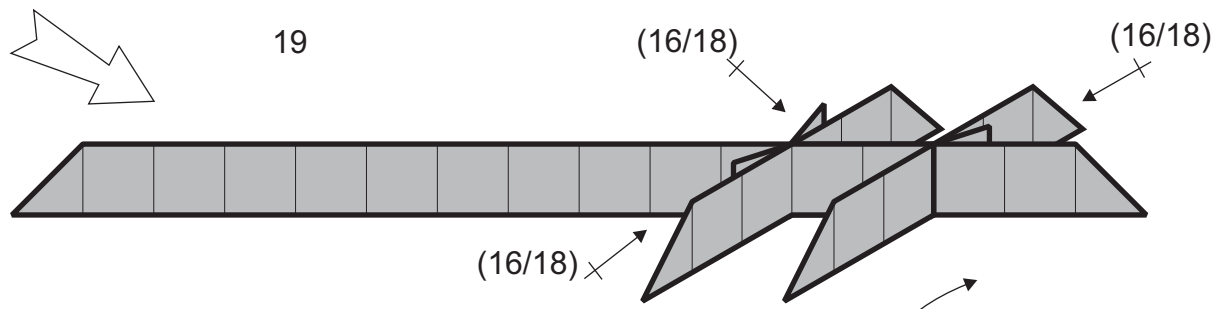

26

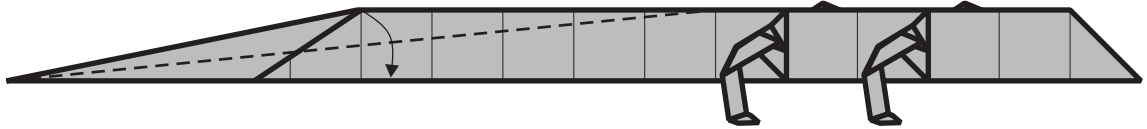

27

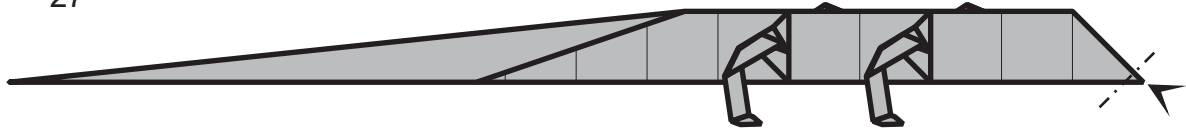

28 dobbiamo arrotondare la testa rendendola tridimensionale

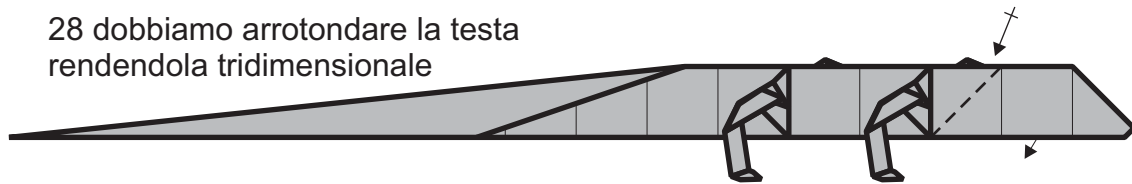

29 schiacciare il corpo rendendolo tridimensionale

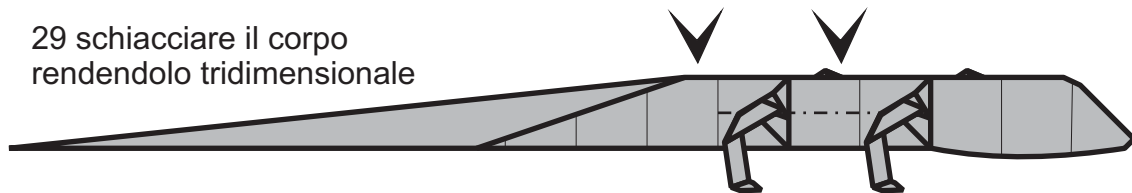

30 modellare tutto il corpo, aiutandosi con una foto, rendendola quanto più realistica è possibile



dimmi un rettile

lucertola

dimmi un altro rettile

un'altra lucertola

31

