

Cigno

di P. D'Auria

<http://digilander.libero.it/origamidauria>

Usare un foglio bianco da entrambi i lati
partire con la base quadrata

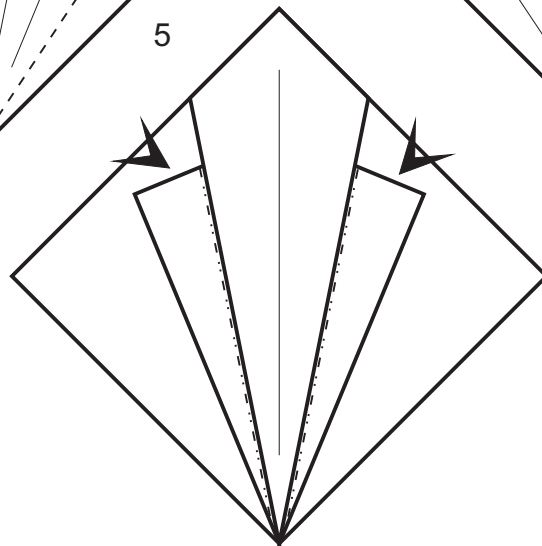
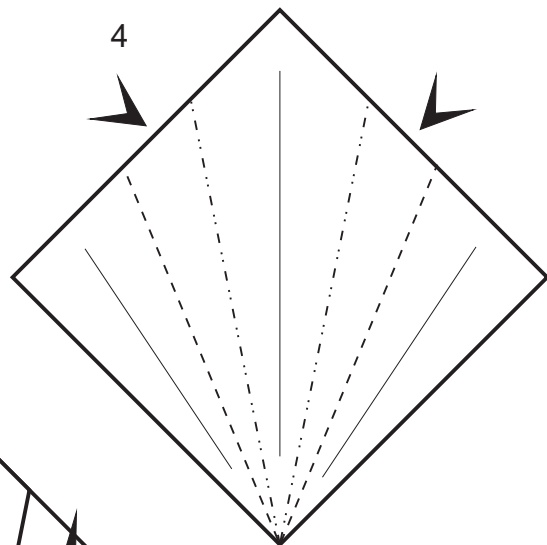
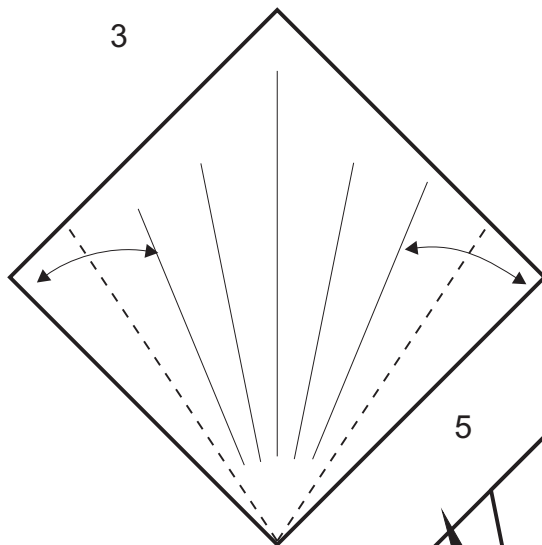
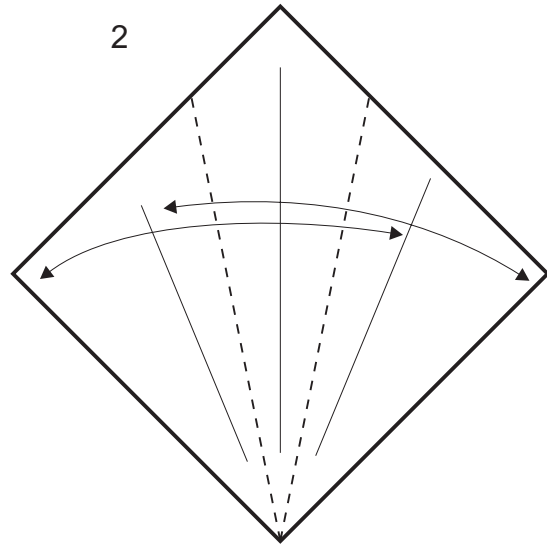
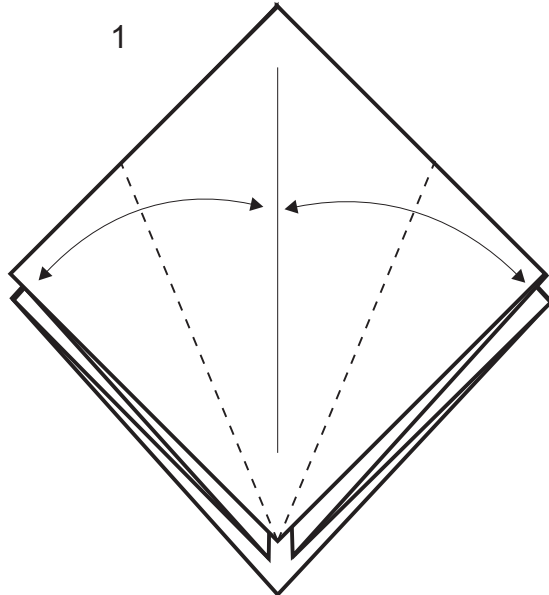

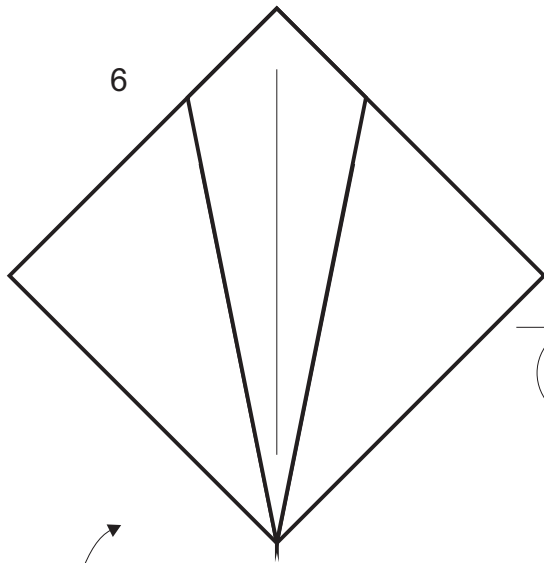

7 ripetere i passi da 1 a 6

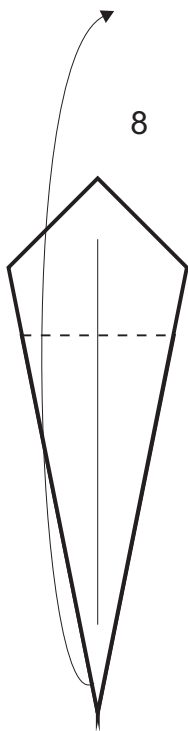
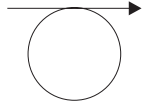
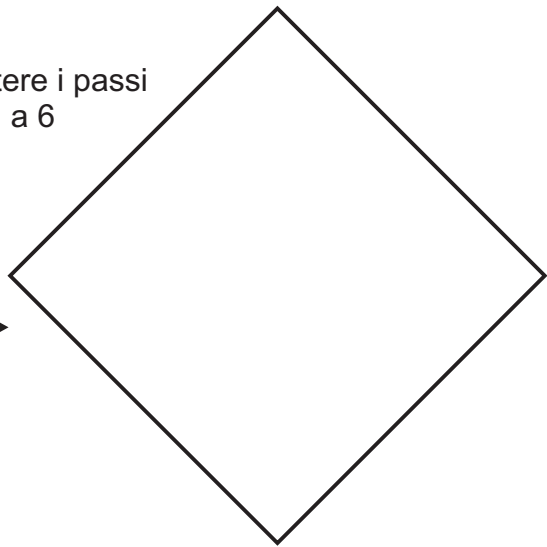

9 questa piega dà tridimensionalità al modello

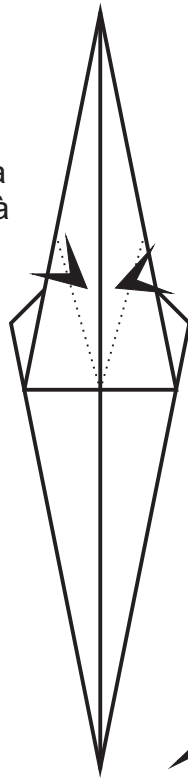

10 il corpo deve essere rovesciato trasformandolo da concavo in convesso

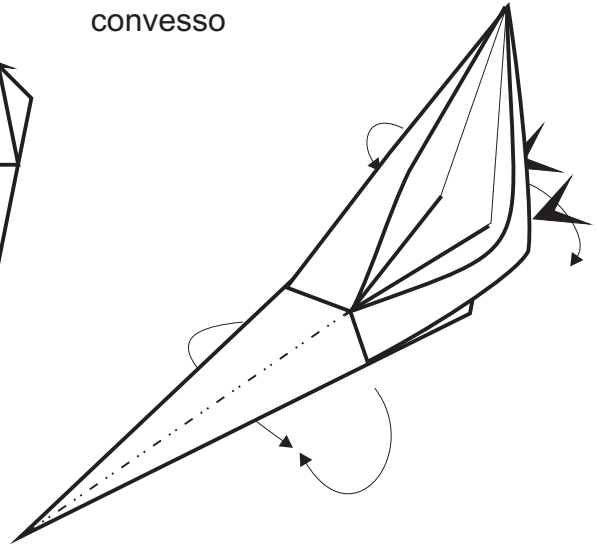

11 b) vista dall'alto, notare la tridimensionalità

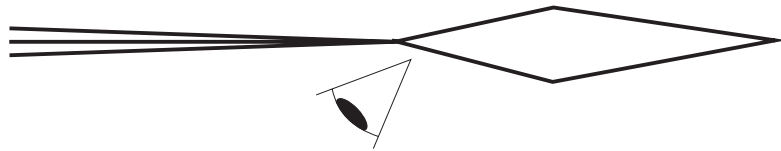

11



12

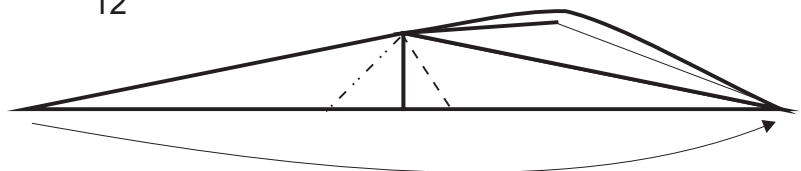

13 questa piega dà tridimensionalità all'ala

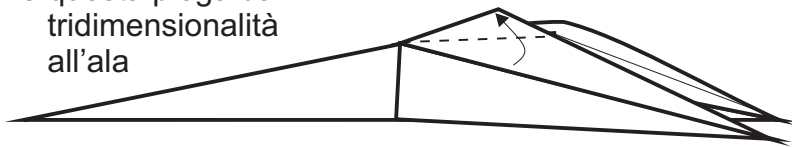

14 l'ala deve essere rovesciata trasformandola da concava in convessa

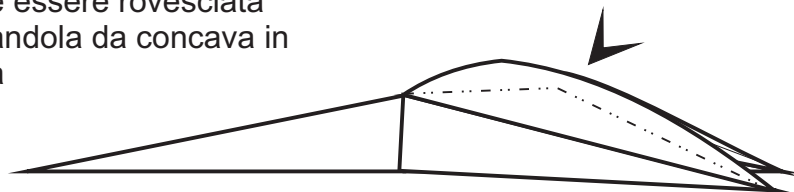

15 ripetere i passi da 12 a 14 sull'altra ala

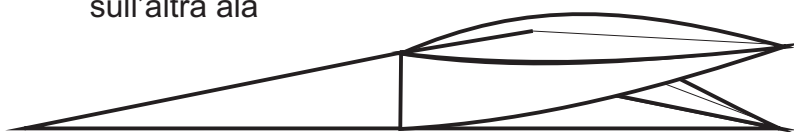

16 b) vista dall'alto



16



17

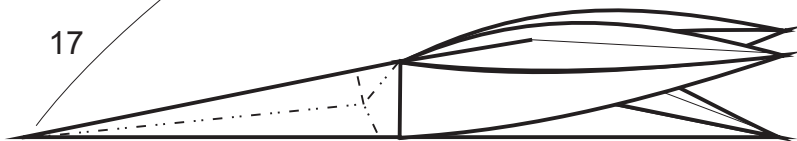

18

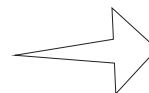
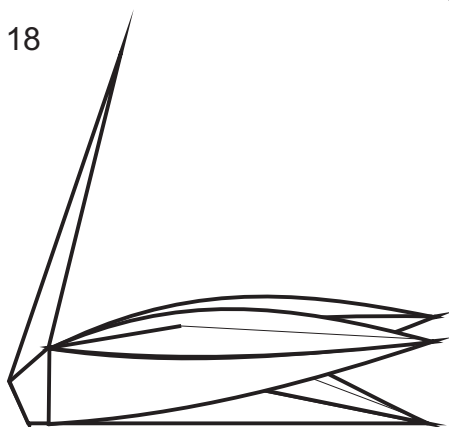

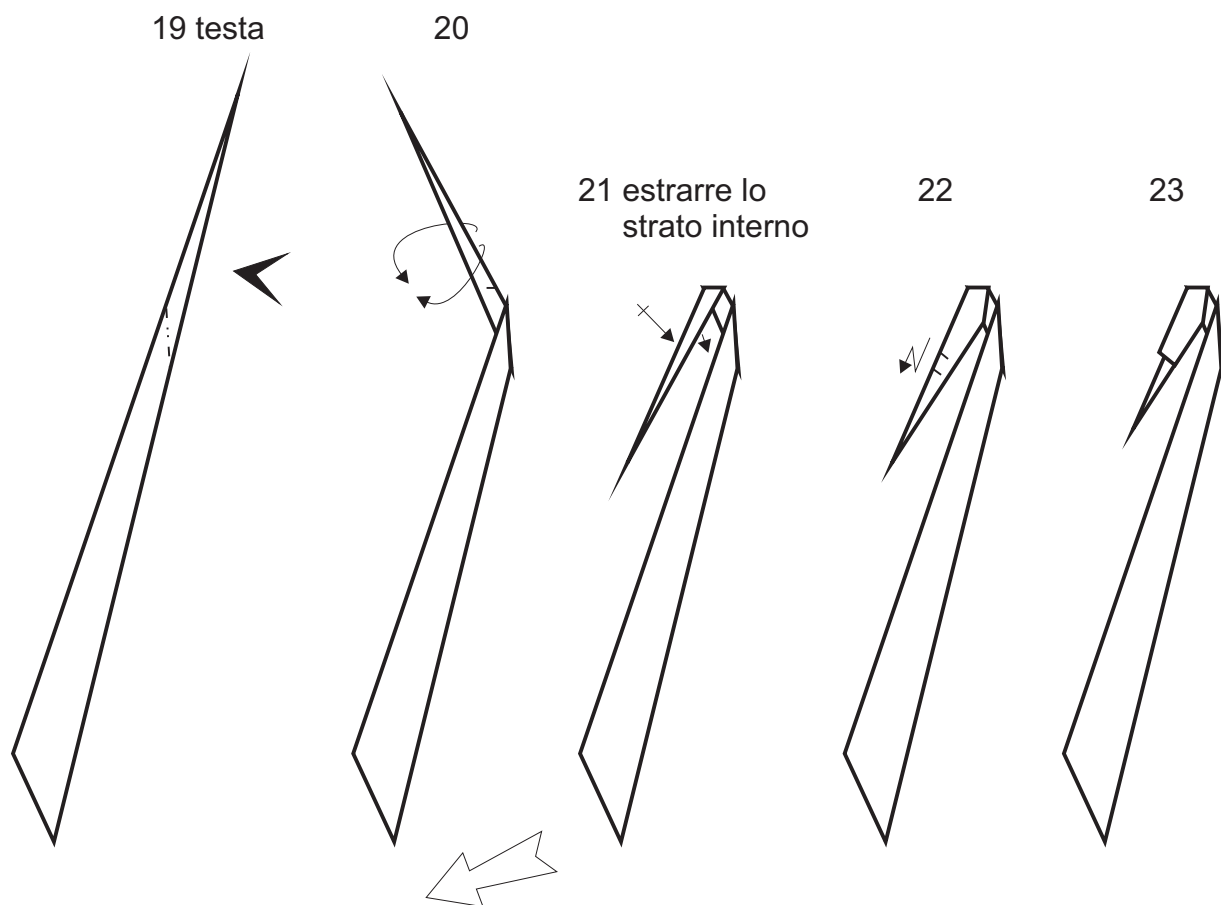

24 coda (per semplificare vediamo il modello senza le ali)

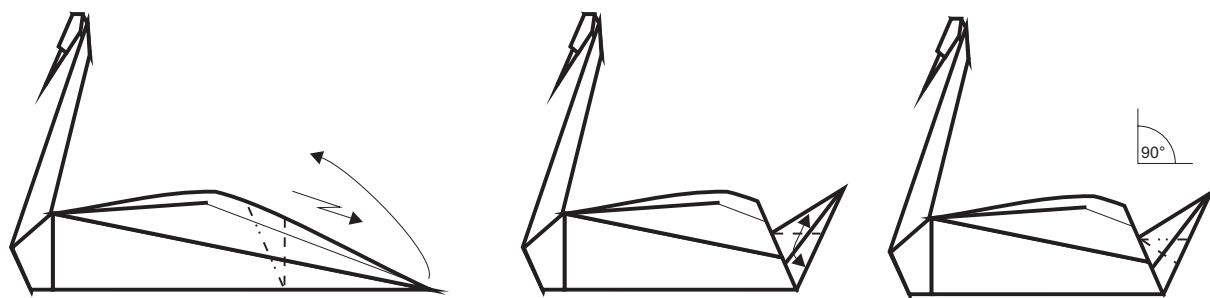

27

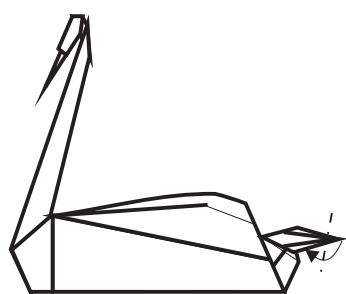

28

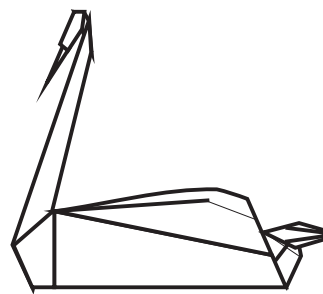

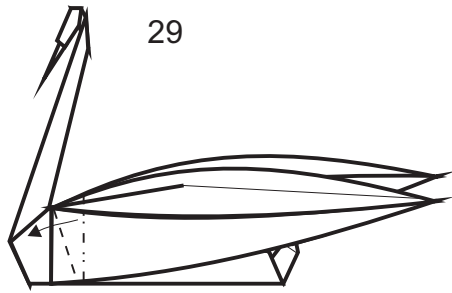

29

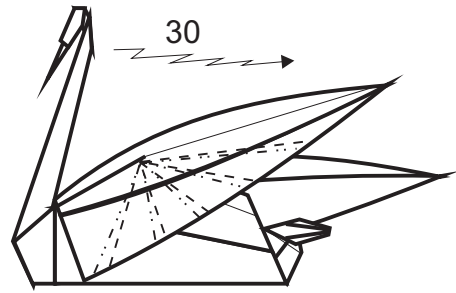

30



31 ripetere i passi da 29 a 30
sull'altra ala

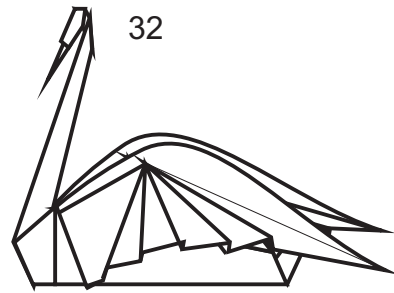

32

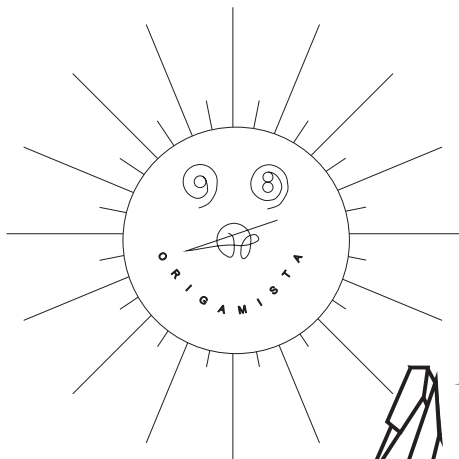

Avere un collo così lungo mi
rende ancora più elegante, ma
quando viene il torcicollo.....

